

# Joule EcoHeat 160L, 200L, 260L Installation & Maintenance Manual



**REGISTER THIS PRODUCT  
ONLINE WITHIN 28 DAYS OF  
COMMISSIONING**

**UNITED KINGDOM / IRELAND**



# Safety Information

This appliance can be used by children aged from 8 years and above and persons with reduced physical, sensory or mental capabilities or lack of experience and knowledge if they have been given supervision or instruction concerning use of the appliance in a safe way and understand the hazards involved. Children shall not play with the appliance. Cleaning and user maintenance shall not be made by children without supervision.

- Hot water may drip from the discharge pipe of the pressure-relief device, this discharge pipe must be left open to the atmosphere.
- The pressure-relief device is to be operated regularly to remove lime deposits and to verify that it is not blocked.
- Drain valves are located on the hot water tank to allow draining of the water from the primary and secondary.
- This appliance is intended to be permanently connected to the water mains and not connected by a hose-set.
- A discharge pipe connected to the pressure relief device must be installed in a downwards direction and in a frost-free environment.
- The Appliance power cable is to be connected to a suitably sized isolator which disconnects all poles with a contact gap of at least 3mm.
- The maximum hot water temperature achievable by the EcoHeat Hot Water Heat Pump is 65°C. The Heat Pump has been tested to EN 16147 :2017+A1:2022 and the function of all Safety devices has been verified.
- WARNING, CAUTION, DANGER removing the front cover of the appliance will give access to live parts!



**Please read maintenance section in this manual before use**

# Preface

Dear installer,

You are about to install a Joule EcoHeat hot water heat pump. This system shall only be commissioned by a qualified installer. You the installer must have been trained by Joule. Systems installed by untrained installers will have no warranty guarantee.

Before you start installing the Joule EcoHeat, please ensure that you have fully read and understood this installation manual. Use the table of contents on the next page to quickly find information.

The warranty terms are 2 years parts and labour on the EcoHeat and all heat pump system accessories supplied by Joule, with 10 years warranty on the unit body. To maintain these warranty guarantees a once yearly service must be carried out by a competent engineer. For further details on the terms and conditions please consult the warranty section of this manual.

The EcoHeat complies with European directives and additional national regulations which are indicated in a CE marking. The corresponding declaration of conformity can be requested from Joule.

The EcoHeat complies with protection class IPX2.

## For more information, please contact:

### Joule UK:

Unit 3, Leftfield Park, Park Road,  
Pontefract,  
West Yorkshire,  
WF8 4PS, UK  
e: [info@jouleuk.co.uk](mailto:info@jouleuk.co.uk)  
t: 0330 808 8488  
f: 0 1513 568 336

### Joule IE:

Unit 407 NW Business Park,  
Cappagh Road, Ballycoolin,  
Blanchardstown, Dublin,  
D11 HD36, IE  
e: [info@joule.ie](mailto:info@joule.ie)  
t: 353 (1) 6237080  
f: 353 (1) 626 9337

# Third Party Certification

## Third Party Certification - Documents handover to the customer

Confirm availability of operation and maintenance document, handover document for client

Y

N

## Third Party Certification - Components check

Is the system safe to operate?

Y

N

Is there adequate access and free space to the system for the purposes of operation and maintenance?

Y

N

Has the system been left in reasonably clean condition?

Y

N

Are all components in good condition?

Y

N

# Installation Checklist

## General

- Is the installation complete with no obvious defects present?
- Has all protection/packaging been removed such that the system is fully functional?
- For ducted systems, has ductwork been installed in such a manner that air resistance and leakage is kept to a minimum?
- Is the ductwork fitted to the correct connections on the heat pump?
- Has the heat pump and all its ductwork been effectively insulated?
- Is all pipework connected correctly?
- Is flow and return pipework connected correctly?
- Has the correct size electrical circuit breaker been installed?
- Has an electrical isolation switch been installed?
- Has the correct size power cable been used for exhaust air heat pump?

See Page 20 for cable requirements

# Table Of Contents

Introduction .....	7
EcoHeat Dimensions .....	15
Technical Specification .....	16
Pre-Installation Notes.....	18
First Fix Notes.....	20
Installation Location .....	21
Ventilation Connection .....	24
EcoHeat Schematic.....	25
General Pipework .....	26
EcoHeat Electrical Connections .....	27
EcoHeat Electrical Schematic .....	29
Commissioning the EcoHeat Unit.....	30
Commissioning Controller .....	31
Maintenance of the EcoHeat .....	43
Spare Parts.....	45
Warranty.....	49
Benchmark Checklist.....	52
Service Record .....	54
Notes.....	56

# Introduction

## General Product Description:

In a similar way to a standard air source heat pump (ASHP) the EcoHeat extracts energy from external outdoor air for the purpose of domestic hot water (DHW) production. After the air runs through the heat pumps evaporator, cooler air is exhausted back outside.

## Who is this manual for?

This manual is intended for the professional installer. The installer must be certified by Joule and have successfully completed the EcoHeat training. The installer does not need to be in possession of a STEK or F-gas certification.

The instructions are an integral part of the appliance and must be given to the end user on completion of the installation in order to comply with the current regulation.

It is important to carefully read the manual to understand all the information to enable safe installation, use and servicing. These instructions consist of details for installation, servicing, fault finding and replacement of parts for the unit purchased.

JOULE will not accept any liability in the event of damage for not complying with the guidance in this instruction manual.

The instructions for this installation manual apply to the range of JOULE EcoHeat.

Safety is paramount when installing unvented hot water systems and the following instructions must be adhered to:

- Only certified competent installers can install, commission and service the equipment supplied.
- The unit must be used for potable hot water only. Any other applications will be considered incorrect use and JOULE will not be held liable for any losses resulting from such use.
- All installation and maintenance instructions must be observed to ensure the correct operation of the equipment.
- The electric immersion must not be switched on unless the is completely full of water.
- Domestic hot water may be stored at temperatures exceeding 60°C. Preventative measures should be put in place to negate the possibility of scalding.
- A maintenance schedule should be put in place with a competent person to service the equipment annually to comply with the warranty conditions.

- When servicing the system the mains supply to the unit should be isolated.
- Only genuine spare parts should be used. A full list of items with relevant codes can be found on page XX.

All current Building Regulations issued by the Department of the Environment, i.e. Building Regulation G3 (England and Wales), Technical Standard P3 (Scotland) or Building Regulation P5 (Northern Ireland) and the Water Fitting Regulations (England and Wales) or Water Byelaws (Scotland). The installation should also be in accordance with the following British Standard Codes of Practice:

BS 5449:1990 Forced circulation hot water systems

BS 5546:2000 Installation of hot water supplies for domestic purposes BS 5918:1989 Solar heating systems for domestic hot water

BS 6700:2006 Design, installation, testing and maintenance of services supplying water.

Failure to install this appliance correctly could lead to prosecution and will invalidate the guarantee. It is in your own interest and that of safety to ensure that the law is complied with.

## Handling

Care must be taken when transporting, storing and installing the equipment:

- At least two people should lift the unit to prevent injuries.
- The unit must be stored in a dry area and must never be dropped during handling.
- Packaging should only be removed at the installation location.
- The unit must be installed on a level floor with the required load bearing capability. Installation, servicing, maintenance and repair must be carried out by a competent person.
- All electrical wiring must be carried out by a qualified electrician and be installed in accordance with current I.E.E Wiring Regulations.
- A lack of safety devices can lead to potentially fatal injuries, all necessary safety devices must be installed correctly in the system. The use of an electric immersion may lead to the build up of electrical potential in the water. This can in turn cause corrosion of the immersion. To prevent this, ensure the immersion heater, and the hot and cold pipework are correctly bonded and connected to the earth line.
- If plastic pipes are used they must be approved temperature resistant to 95°C at a pressure of 10bar.

A thermostatic mixer should be installed in the system to prevent the risk of scalding. If there are leaks found in the system, shut off the cold water stop valve from the main supply and contact a competent person immediately.



## What Is Benchmark?

Benchmark places responsibilities on both manufacturers and installers. The purpose is to ensure that customers are provided with the correct equipment for their needs, that it is installed, commissioned and serviced in accordance with the manufacturer's instructions by competent persons and that it meets the requirements of the appropriate Building Regulations.

The Benchmark Checklist can be used to demonstrate compliance with Building Regulations and should be provided to the customer for future reference. Installers are required to carry out installation, commissioning and servicing work in accordance with the Benchmark Code of Practice which is available from the Heating and Hot Water Industry Council who manage and promote the scheme. Visit [www.centralheating.co.uk](http://www.centralheating.co.uk)

## HWA Charter Member

Joule are proud to be a charter member of the the Hot Water Association (HWA), that has been formed through the union of the two UK industry trade bodies, WMA (Water Heater Manufacturers Association) and MODUS (Manufacturers Of Domestic Unvented Systems).

The objectives of the HWA are "To be recognised as the leading body in domestic hot water storage and, through cooperation and partnerships, to support, drive and promote the sustained growth and improvement of standards within the entire domestic hot water industry".

The HWA operate a Charter that all members of the association observe.

The HWA Charter Statement requires that all members adhere to the following:

To supply fit for purpose products clearly and honestly described

- To supply products that meet or exceed appropriate standards and Building And Water Regulations
- To provide pre and post technical support
- To provide clear and concise warranty details to customers

## Water Supply

The performance of any unvented system is only as good as the mains water supply available. To this effect the maximum possible water demand should be assessed, with the knowledge that the mains supplies both hot and cold services simultaneously. The water heater itself operates at a pressure of 3bar, controlled by the inlet control set, and is capable of delivering over 50 litres per minute. The high quality inlet control set has been designed to make the most of the low rates available.

The water supply should be checked to ensure it can meet these requirements. If necessary, consult the local water authority regarding the likely pressure and flow rate availability.

Consideration should be given to upgrading existing 1/2" (15mm) cold mains pipework to a larger size if the recommended minimum pressure / flow rate is not being achieved. JOULE recommend that primary pipework used has a minimum diameter of 22mm to ensure low pressure loss.



**A high static (no flow) mains pressure is no guarantee of good flow availability. In a domestic installation 1.5bar and 25ltr/min should be regarded as the minimum. The maximum mains pressure that the inlet control set can cope with is 10bar.**

## Change Of Water Supply

The changing or alternating from one water supply to another can have a detrimental effect on the operation and/or life expectation of the water heater storage unit, pressure temperature relief valve and heating unit.

Where there is a changeover from one water supply to another, e.g. a rainwater tank supply, bore water supply, desalinated water supply, public reticulated water supply or water brought in from another supply, then water chemistry information should be sought from the supplier or it should be tested to ensure the water supply meets the requirements given in these guidelines for the Joule warranty to apply.

## Water Chemistry

This water heater must be installed in accordance with this advice to be covered by the Joule warranty. This water heater is manufactured to suit the water conditions of most public reticulated water supplies. However, there are some known water chemistries which can have detrimental effects on the water heater and its operation and/or life expectancy. If you are unsure of your water chemistry, you may be able to obtain information from your local water supply authority. We recommend not to use water softener, however if it is used the water is required to be kept at potable standards. This water heater should only be connected to a water supply which complies with these guidelines for the JOULE warranty to apply.

## Water Chemistry Levels Affecting Warranty

The JOULE warranty of this water heater will not cover resultant faults on components including the storage unit where water stored in the storage unit exceeds at any time any of the following levels:

Components	Maximum Permitted Levels
Total Dissolved Solids	600 mg/litre
Total Hardness	200 mg/litre
Chloride	300 mg/litre
Magnesium	10 mg/litre
Calcium	20 mg/litre
Sodium	150 mg/litre
Iron	1 mg/litre
Maximum pH	9.5
Minimum pH	6.5

## Total Dissolved Solids (TDS)

Some water analysis reports may state the conductivity of the water rather than the level of total dissolved solids. Conductivity, measured in microsiemens per centimetre ( $\mu\text{S}/\text{cm}$ ), is directly proportional to the TDS content of the water. TDS, in  $\text{mg}/\text{L}$ , is approximately 70% of the conductivity in  $\mu\text{S}/\text{cm}$ .

The JOULE warranty will not cover resultant faults to the storage unit if this water heater is connected at anytime to a water supply where the TDS content of the water exceeds 600  $\text{mg}/\text{L}$ . In locations where TDS approaches 600  $\text{mg}/\text{L}$ , e.g. due to sediment, we strongly recommend fitting an appropriate filter to ensure water entering or in the water heater does not exceed this level at any time i.e. due to sediment build up.

## Features Of The EcoHeat

Made from Duplex Stainless Steel for excellent corrosion resistance.

- Strong rust-proofed steel case.
- Insulation is by means of an approved CFC/HCFC free polyurethane foam with an ozone depletion factor of zero.
- Available in a variety of sizes to suit - 90L, 120L, 150L, 180L, 210L, 250L and 300 litres.
- All models including Solar models are available in Twin coil versions supplied complete with all the necessary safety and control devices needed to connect to cold water mains
- All safety and control devices are pre-set.
- High quality controls selected that combine high flow rate performance with minimum pressure drop which gives fantastic performance in all areas, with great improvements in areas with poor water pressure.

## Nameplate and symbols on the product

Important information about your unit can be found on a rating plate as well as other symbols located on the product.

## The Type Plate

The Type Plate provides information about the unit. The Type Plate is located in two places on and in the EcoHeat unit shown:

### EcoHeat Type Plate:

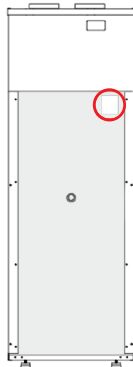
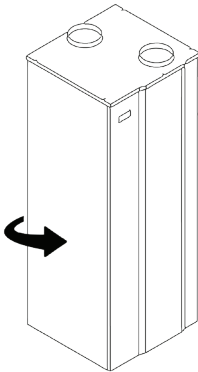

**joule**  
Manufacturing Excellence



Modelo/Model:	EH160
Num. serie/Serial Num.:	EH06231057
Alimentac. Elec.:	230V/1ph/50Hz
Power supply:	
Potencia térmica media, BC:	1800 W
Rated heating capacity, HP:	
Potencia consumida media, BC:	500 W
Rated power input, HP:	
Potencia Resist. Elec.:	1500 W
Electrical Heat. Input:	
Volumen del tanque:	160 L
Tank volume:	
Preción max. operac. aqua:	6 bar
Max. Operating pressure:	
Peso neto:	79 kg
Net weight:	
Refrigerante:	134A/950 g
Refrigerant:	
Preción lado baja:	2 bar
Low - Pressure side:	
Preción lado alta:	25 bar
High - Pressure side:	

<Vacío>

## Article Number

Indicates the exact model version of that specific unit

## Serial Number

This is a unique number specific to the unit that can be used to identify the EcoHeat during installation or maintenance.

## QR Code

A QR code is placed on the inside of the EcoHeat. The digital warranty card can be filled in by scanning the QR code. This is then automatically sent to Joule and the installer.

## Version

The design/manufacturing version

## Symbols

The symbols on the Type Plate and on the EcoHeat mean the following:



CE MARKING

This is the CE logo with which Joule indicates that the product meets the legal requirements.



FOR INDOOR USE ONLY

This symbol indicates that the EcoHeat may only be used indoors.



READ THE MANUAL

This symbol indicates to the user that the manual should be consulted.



WEEE MARKING

This symbol indicates that the product must not be disposed of with household waste. The product must be collected separately.



LOGO MATERIAL CODE PP

This logo is applied to the housing and indicates the use of polypropylene.



LOGO MATERIAL CODE ABS

This logo is applied to the housing and indicates the use of ABS.

# EcoHeat Dimensions

The dimensions covering the EcoHeat configuration is shown below:

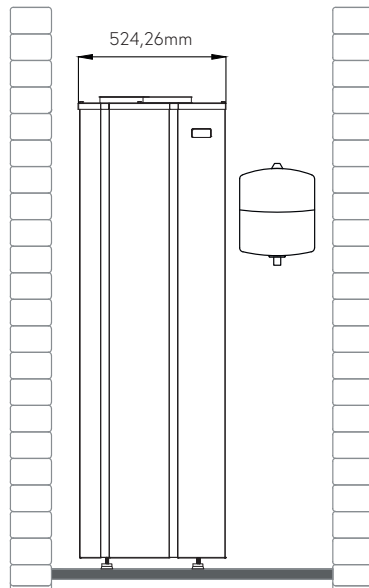
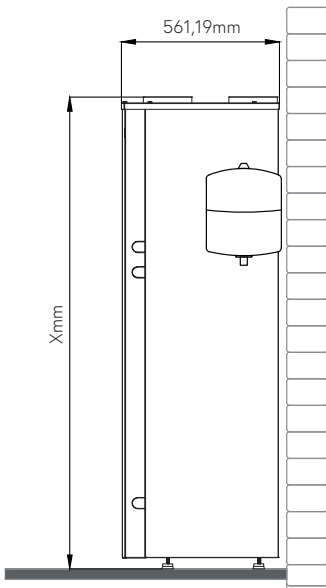
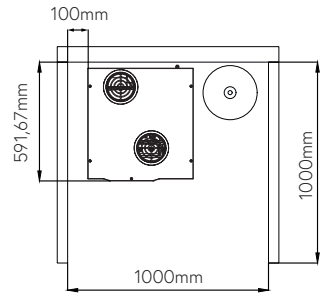

DIMENSIONS AND WEIGHT				
Height (x)	mm	1297	1527	1945
Width	mm	585	585	585
Depth	mm	615	615	615
Weight	kg	55	58	63
CONNECTIONS				
Air inlet/outlet	mm	150/160/200	150/160/200	150/160/200
Hot water outlet	Inch	¾"	¾"	¾"
T&P	Inch	½"	½"	½"
Cold water inlet	Inch	¾"	¾"	¾"
Coil connections	Inch	-	-	¾"
Condensate drain	Inch	¾"	¾"	¾"

# Technical Specification

SPECIFICATIONS	UNIT	Model Type		
		EcoHeat 160	EcoHeat 200	EcoHeat 260
Mains connection		P+N230V ~50Hz ±6%”	P+N230V ~50Hz ±6%”	P+N230V ~50Hz ±6%”
Fuse	A	16	16	16
Max. power consumption heat pump	W	496 - 600	496 - 600	496 - 600
Max. output heat pump	W	1100 - 1841	1100 - 1841	1100 - 1841
Outdoor Air Temp Range	°C	-5/35	-5/35	-5/35
Max. power consumption DHW Tank element	W	1500	1500	1500X
Average electrical consumption power heat pump	W	496 - 600	496 - 600	496 - 600
IP Class		X2	X2	X2
Max. working pressure	bar	6	6	6
Cord type		3 core cableflex (1.5 m)	3 core cableflex (1.5 m)	3 core cableflex (1.5 m)
PERFORMANCE				
Max. water temp. HP/ HP+Immersion	°C	55/70	55/70	55/70
Energy Efficiency Class		A	A	A
Load Profile		L	L	XL
SCOP(14°C)		2.8	3.1	3.0
REFRIGERANT				
Refrigerant	Type	R134a	R134a	R134a
Refrigerant content	g	580	580	580
GWP Value		1430	1430	1430
C02 equivalent	kg	830	830	830



INSTALLATION ROOM				
Max. permissible air humidity installation room	rH	85%	85%	85%
Max. allowed temperature	°C	35	35	35
Min. allowed temperature	°C	10	10	10
CONNECTIONS				
Air inlet/outlet	mm	150/160/200	150/160/200	150/160/200
Hot water outlet	Inch	¾"	¾"	¾"
T&P	Inch	½"	½"	½"
Cold water inlet	Inch	¾"	¾"	¾"
Coil connections	Inch	-	-	¾"
Condensate drain	Inch	¾"	¾"	¾"
VENTILATION				
Air flow rate	m <sup>3</sup> /h	350	350	350
Max. pressure drop	Pa	70	70	70
Low setting (set value)	m <sup>3</sup> /h	50 - 350	50 - 350	50 - 350

# Pre-Installation Notes

- Always store the EcoHeat vertically
- Store the manual in a safe place in order to be able to use it as reference after installation. For maximum safety installers should always read the following warnings carefully.
- Store the provided manual in a safe location with the end user after installation and remember to hand it over to the new end user if the Heat Pump & Tank unit is sold or transferred.
- Only remove the device from the box at the installation site. Secure the device against falling.
- The EcoHeat is compliant with the requirements of the Low Voltage Directive (2014/35/ EU), the EMC Directive (2014/30/EU) and the pressure equipment directive (2014/68/EU).
- The manufacturers shall not be responsible for damage originating from unauthorised changes or the improper connection of electric and hydraulic lines.
- Do not use units if you see some damage on them and notice something untoward such as loud noise, smell or burning.
- In order to prevent electric shocks, fires or injuries, always stop the unit, disable the protection switch and contact Joule's technical support if the unit produces smoke, if the power cable is hot or damaged, or if the unit is very noisy.
- Handle electrical appliances with care. Never touch the device with wet hands, never touch the device when you are barefoot.
- Always remember to inspect the unit, electric connections, refrigerant tubes and protections regularly. These operations shall be performed by qualified personnel only.
- The unit contains moving parts and electrical parts which should always be kept out of the reach of children.
- Unauthorised personnel should not attempt to repair, move, alter or reinstall the unit. These operations may cause product damage, electric shock and fires.
- Do not place containers with liquids or other objects on the unit.
- Under no circumstances must the compressor block be opened or damaged.
- All the materials used for the manufacture and packaging of the Exhaust Air heat pump are recyclable. The packaging material and exhausted batteries of the remote controller (optional) must be disposed of in accordance with local regulations.
- The EcoHeat contains a refrigerant and must be disposed in an authorised centre or returned to the retailer as special waste.

- To avoid your hands being injured by the edge of the parts wear protective gloves to unpack, move, install, and service the unit. Do not touch the internal parts (water pipes, refrigerant pipes, heat exchangers, etc) while running the units. If you need to adjust and touch the units, allow sufficient time for the unit to cool and be sure to wear suitable personal protective equipment.
- In case of a refrigerant leakage, try to avoid contact with the refrigerant as this could result in serious injury.
- It is only permitted to install the EcoHeat in a room that is free of frost.

# First Fix Notes

## Primary Pipework from Heat Pump

- The pipework should be fully insulated and protected from water and moisture.
- The supplied flexible hose should be used for piping the condense outlet only, providing a suitable air gap to the drain connection.
- The ducting should be adequately insulated to mitigate any moisture build up.

## Electrical Supply and Cable Requirements

- The heat pump is supplied with a 1.5 metre supply cord. Ensure the mains supply connection is made through a suitable isolator switch that can provide disconnection of all poles, with a minimum separation of 3mm.
- Power supply to heat pump to be terminated with a suitable isolator located next to the unit.
- Tank Immersion maximum allowed output of 3kW, connection of immersion with greater power draw will cause irreparable damage to Heat Pump controller board.
- When installing the Heat Pump take great care to install as per the detailed notes for installation locations. The Heat Pump must have minimum clearance of 300mm at the top and 500mm to the front of the unit.
- The Heat Pump must not be installed in a location without these clearances available.
- Condensation will form inside the Heat Pump during normal operation, this is normal. Ensure the correct pipework is used and that it has a continuous fall to the drain connection. An adequate air gap is also required to allow the water to drain correctly.
- The Heat Pump must be installed vertically and be plumb and level.



**Tank Immersions connected to the EcoHeat must have a power input of 3kW or less**

# Installation Location

## Restrictions around the EcoHeat Heat Pump

Certain clearance distances must be adhered to prior to citing an area for installing the unit. Clearance is required to provide sufficient space for installation and maintenance.

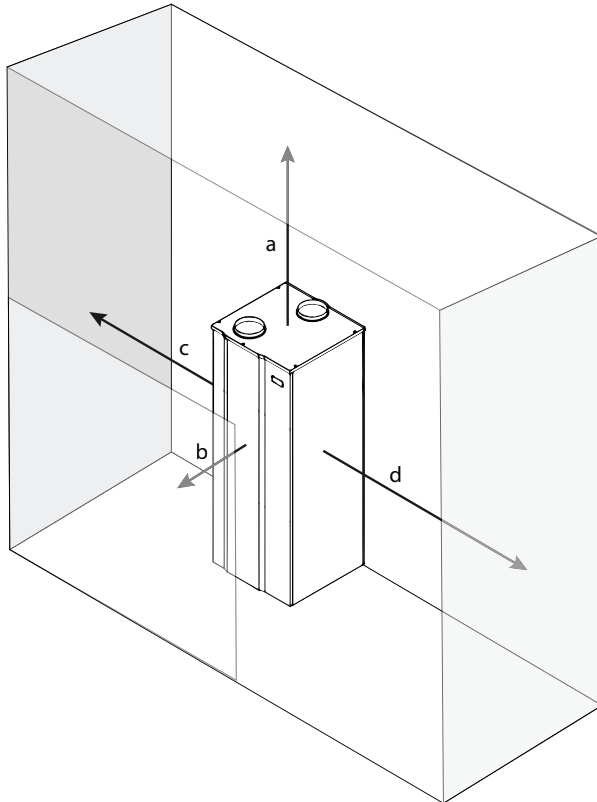

Minimum Required space around the Eco-Heat Unit	
a	min. 300mm
b	min. 500mm
c	min. 10mm
d	min. 10mm

## Connecting to the ventilation ductwork

The ventilation ductwork system is essential to the performance of an Hot Water Heat Pump. To avoid under performance of the Heat Pump or increased system noise, the following points should be considered when designing/ installing the ductwork:

- Avoid sharp bends or transitions.
- Swept 90° bends or 2x45° bends are preferred.
- Use two 45° bends instead of one 90° bend
- Ensure all burrs are removed from duct ends.
- Insulated flexible ducts must be used to connect the ductwork to the Heat Pump.
- Ensure all joints and connections are sealed appropriately
- The maximum pressure drop across the external grille of the exhaust duct shall not exceed 8 Pa.
- The maximum permissible pressure drop for the entire duct system shall not exceed 150 Pa (excluding the Heat Pump).
- The pressure drop across the Heat Pump is 30 Pa

## Installation Possibilities

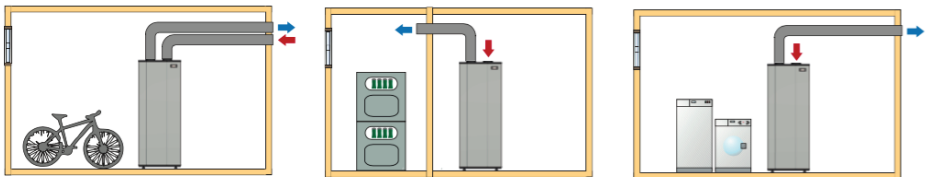

## Ductwork – Supply Air

The Supply Air or 'Air In' to the Heat Pump is the heat source to the Heat Pump system. The extract air is fed via the ductwork to the Heat Pump from outside the dwelling.

## Ductwork – Exhaust Air

The Exhaust Air or 'Air Out' from the Heat Pump is the exhaust of the cooled air from the Heat Pump to outside the dwelling.

It is essential both Supply & Exhaust duct is. When the duct passes through ceiling voids, condensation on the outside of the duct will occur. To avoid this, the entire exhaust duct must be insulated with suitably sized insulation, to local building regulations. The exhaust ducting from the unit should be connected to the roof/wall terminal using a suitably insulated adapter and grill.

The exhaust ducting should be no less than Ø150mm or 220mm x 90mm flat pack. It is necessary to adhere to this duct specification to comply with noise specifications and to prevent potential condensation. 220mm x 90mm flat pack ducting must terminate with a double air brick.



**Ductwork insulation MUST be fully sealed at all joints, transitions, air bricks and/or roof cowls.**

# Ventilation Connection

## Ductwork – Insulation Specification

Provision of insulation to ducts and pipes, in accordance with the standards specified in BS 5422:2009, should adequately limit heat loss or heat gain, as appropriate.

## Ductwork – Unheated Spaces

Any supply or extract ductwork passing through an unheated space must be suitably insulated to avoid condensation and/or heat loss or heat gain. A ceiling void is not considered an unheated space as it is directly above a heated space.

## Ductwork – Exhaust in heated Spaces

Any exhaust ductwork passing through a heated space must be suitably insulated to avoid condensation and/or heat gain.



# EcoHeat Schematic

## Mechanical Diagram

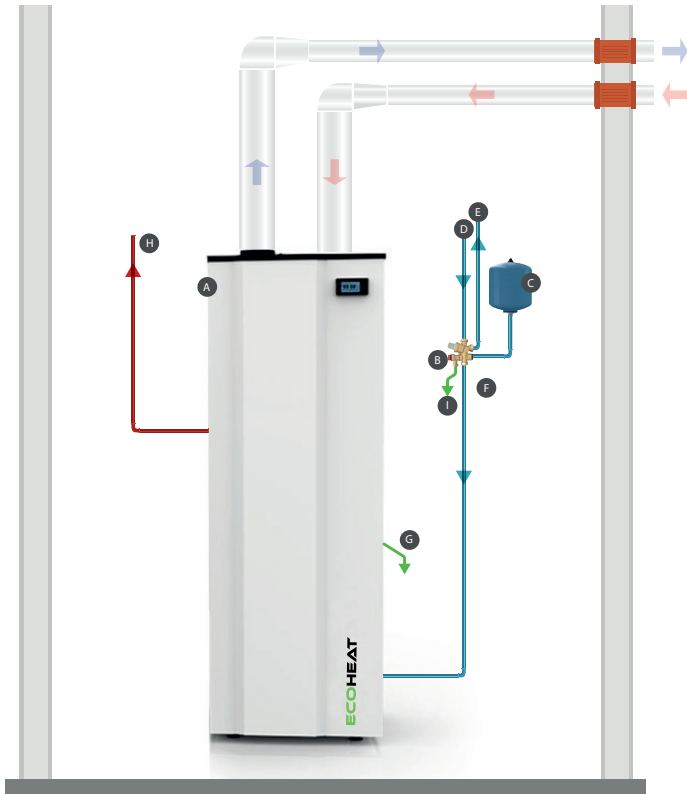

	Description
A	EcoHeat Unit
B	Inlet Control Group
C	Potable Expansion Vessel
D	Mains/Boosted Cold Inlet
E	Balanced Cold Outlet
F	Cylinder Cold Feed
G	Condensate/T&P Safety waste
H	Hot Water Outlet
I	Safety relief valve

# General Pipework

## Connecting the Drain Hose

The Heat Pump absorbs heat from the extracted indoor air. The moisture in the air condenses on the cold evaporator. The condensation water must be drained from the unit to allow the unit to function normally. That is why the Heat Pump must be connected to a drain pipe.

To connect the EcoHeat to the drainpipe:

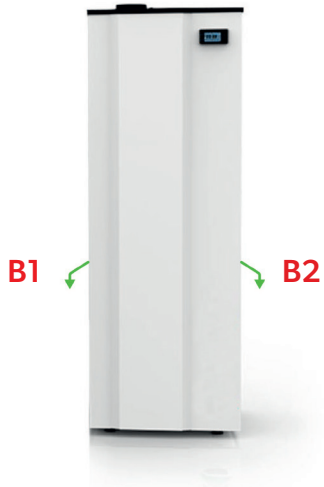
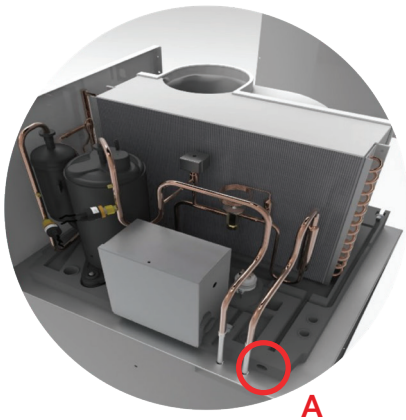

1. Connect the drain hose supplied to the condensate connection of the heatpump (A).

2. Depending on your installation, the drain hose can exit the product at points (B1) (B2).

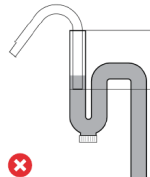
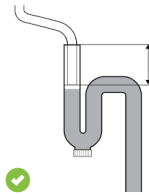

3. Make sure the drain hose is above the water level of the siphon.

# EcoHeat Electrical Connections

## Power Specification

Unit	HZ	Volts	Phase	Starting Current	Mains Fuse
EcoHeat 160//200/260	50	230	Single	10 Amp	16 Amp

- The Heat Pump MUST be connected to the mains through a suitably sized RCBO.
- The power cable is pre-wired from the Heat Pump.
- This Equipment complies with IEC 61000-3-12.
- If extension of the power cable is required, use the grade H05V2V2-F or equivalent materials.
- Ensure that main supply connection is made through a switch that disconnects all poles, with contact gap of a least 3 mm.
- Devices disconnected from the power supply should be completely disconnected in the condition of overvoltage category III.
- Keep distances of 20mm or more between power cable and communication cables.



During the unit installation, first install the ventilation connections, then the piping connections and then finally the electrical connections.  
If the unit is being uninstalled disconnect it in a reverse procedure to the above

# EcoHeat Electrical Connections

## Power Specification

The Heat Pump power cable is to be connected to a suitably sized isolator which disconnects all poles with a contact gap of at least 3mm. The isolation switch is not standard with the EcoHeat supplied. The Isolator allows for disconnection of the electrical power supply for maintenance and/or repair of the Heat Pump.

The Heat Pump is to be wired to the mains through use of a suitably sized RCBO.

Check all connections and the mains voltage is correct before powering On the Heat Pump to prevent damage to the Heat Pumps electronics.

If the power cable is damaged, contact Joule to have it repaired before powering On the Heat Pump. The electrical installation must be carried out by a suitably qualified electrician or under the supervision of one. All installation work and cabling must comply to local building regulations .



**The Heat Pump MUST not be powered on unless the system is filled with water and at the recommended pressure.**

# EcoHeat Electrical Schematic

The power supply of the system is 230 V/1/50 Hz. The power line must be protected by a circuit breaker of 2 poles / 16 A.

The connection scheme is shown in the picture above.

**PV:** Photovoltaic connection

**LPS:** Low pressure switch

**HPS:** High pressure switch

**NTC1:** Water temperature probe

**NTC2:** Evaporator temperature probe

**D:** Display

**VS:** Solenoid valve

**R:** Electrical heater

**K:** Compressor

**F:** Fan

**230 VAC:** Power supply

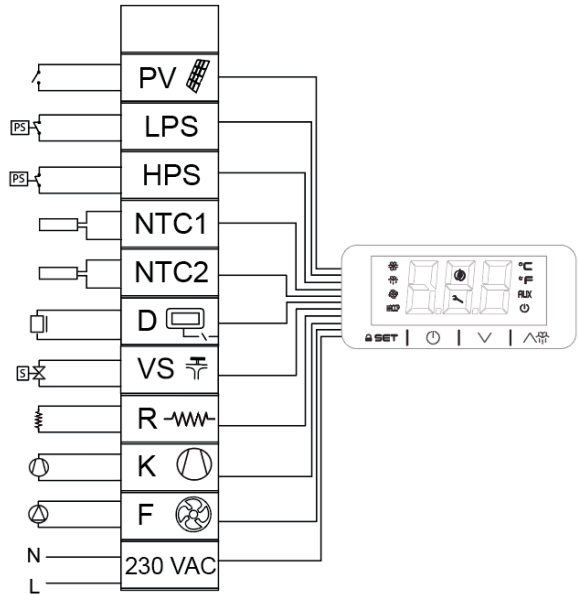

# Commissioning the EcoHeat Unit





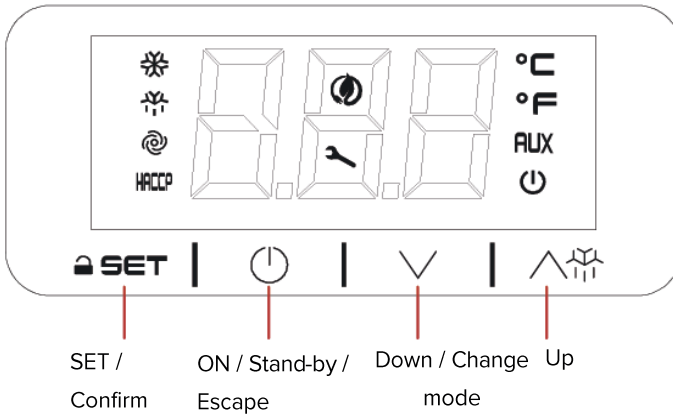

## Preface

To be able to commission the EcoHeat system correctly specific knowledge is required. If you are not certified by Joule, you may not put the EcoHeat into operation. To be certified by Joule the installer must have successfully completed the Joule EcoHeat training course. If you do not meet these requirements, please contact Joule directly to enquire about booking a place in one of our training sessions. The installer of the EcoHeat system does not need to be in possession of a STEK or F-gas approval to be able to install the EcoHeat system.

# Commissioning Controller

## User interface description



Symbol	Meaning when it lights
	Compressor switched on
	Defrost active
	Fan switched on
<b>HACCP</b>	Alarm active
	Compressor working hours exceeded
	Unit in °C
	Unit in °F
<b>AUX</b>	Electric heater switched on
	Stand by

## Installation - Switching ON

After full installation of the water heater (power and water pipes connected) and after the water heater tank is full of water, power can be turn ON.

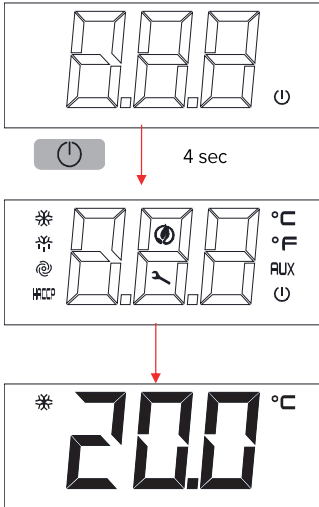

1. After filling the tank of water, connect the mains plug to the mains supply.

The screen will show the  symbol.

2. Hold the  key for 4 seconds. The display will show the icons.

3. The screen will show the water temperature

## Switching OFF

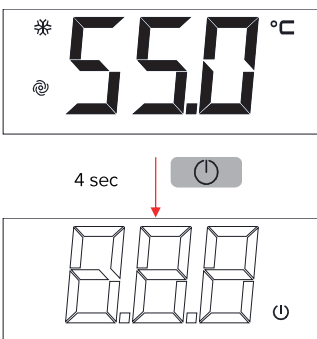

To switch off the system, hold the  key for 4 seconds



## Unlocking the keypad

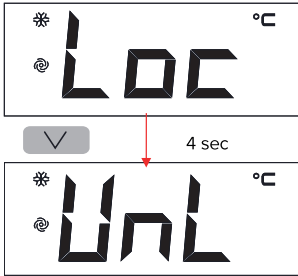

When 30 have elapsed without the keys being pressed, the display will show the " LOC " label and the keypad will lock automatically

Touch any key until the screen shows **UnL**, to unlock the keypad

## Displaying the operating mode

At first initial power ON, the product goes, by default, in Eco mode. By touching one time the key, the controller will show the mode in operation in this moment.

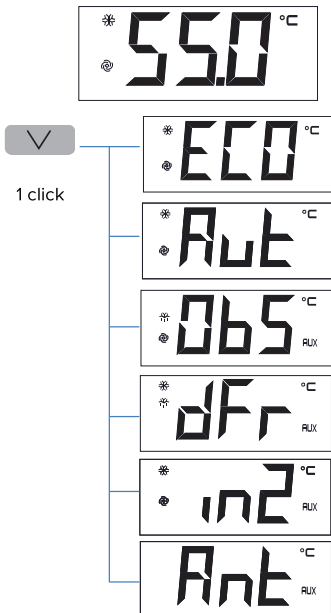

**ECO Mode:** Heating only by heat pump technology

**Auto Mode:** Heating by heat pump and electric heater only if the water temperature falls drastically

**OverBoost Mode:** Simultaneously heating by heat pump and electrical heater to achieve the temperature setpoint as quickly as possible.



**Defrost:** Defrost cycle active

**Photovoltaics / Timer:** Automatic working due to the existence of surplus energy from PV installation or Off-Peak Rate

**Antilegionella:** Automatic disinfection by thermal shock

## Changing operating mode



To change the operating mode, touch the  key for 4 seconds. The screen will show blinking the selectable operating modes. Use the  and  keys to select the operating mode.



Touch  to confirm or  to cancel

The screen will show again the water temperature

## ECO Mode

ECO mode: Maximum savings . The system heats water only by heat pump technology. This is the factory default mode.

### Setting the ECO temperature setpoint

The water temperature set point in ECO mode can be changed with the **SP1** parameter.

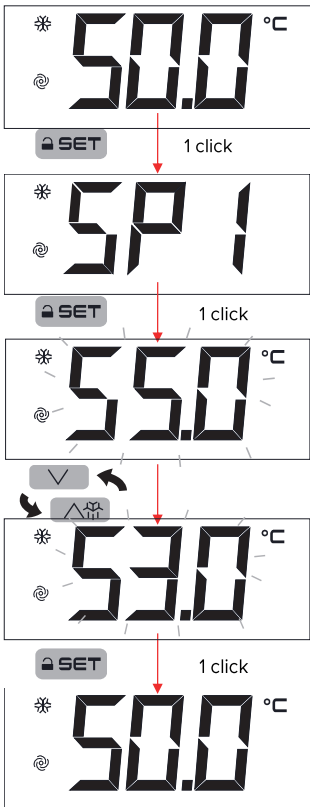

Touch **SET** key and select SP1. Touch **SET** to confirm.

The display will show the programmed temperature

Touch **▽** or **△** to select the desired temperature

Touch **SET** to confirm or **⏻** to cancel

## AUTO Mode

It maintains a steady temperature by the heat pump and only use the electrical heater if the temperature falls drastically.

### Setting the AUTO temperature setpoint

The water temperature set point in AUTO mode can be changed with the **SP2** parameter.



Touch **SET** key and select SP1. Touch **SET** to confirm.

The display will show the programmed temperature

Touch **▼** or **▲** to select the desired temperature

Touch **SET** to confirm or **⏻** to cancel

## OVERBOOST Mode

Select this mode to achieve a fast heating by using simultaneously heat pump and electric heater.

**This mode Works as a rapid heating. Once the setpoint temperature is reached, the system returns to the initial mode.**

- If Overboost mode is switched on when the system Works from **ECO mode**: The system heats the water up to **SP1** , and then returns to ECO again
- If Overboost mode is switch ed on when the system Works from **Auto mode**: The system heats the water up to **SP2**, and then returns to Auto again

When Overboost mode is active, the display automatically changes showing the water temperature and **Obs.**



### Cancelling the Overboost Mode

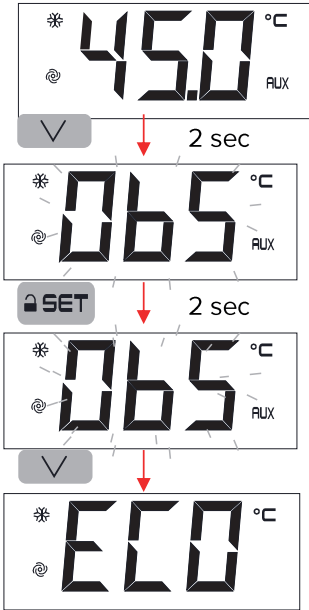

Touch  for 2 seconds, **Obs** will blink on the screen

Touch  for 2 seconds, **Obs** will blink faster

Touch  and the mode will be changed for the initial mode.

**Parameter SP3** allows to set the minimum temperature that Overboost can be activated.

To change its value, follow the procedure:

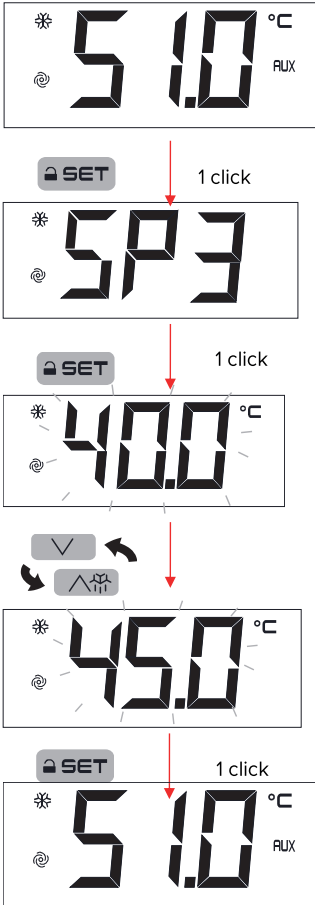

Touch **SET** and select with **∨** and **∧** SP3. Touch **SET** to confirm.

The display will show the programmed temperature

Touch **∨** or **∧** to select the desired temperature

Touch **SET** to confirm or **⏻** to cancel

## Photovoltaic input

Working on this mode, the system automatically heats the water due to electric energy surplus or by Off Peak rate.

The parameters of this mode can only be changed by the Installer's Menu.

Contact with the technician for more information

The system can be combined with and Photovoltaic Inverter to take advantage of the surplus energy generated by the panels, by forcing the system working and storing this energy in useful hot water.

The system has in the electric boar two terminals to connect a zero -voltage contact.



When the contact is closed, the system automatically changes to Photovoltaic mode and the heat pump and electric heater work to achieve the programmed temperature.

When the contact is opened, the system returns to the previous mode.

This contact can be also used for Off Peak Rates. To do it, connect into the contact a timer with a zero -voltage output .



## Displaying/deleting compressor functioning hours

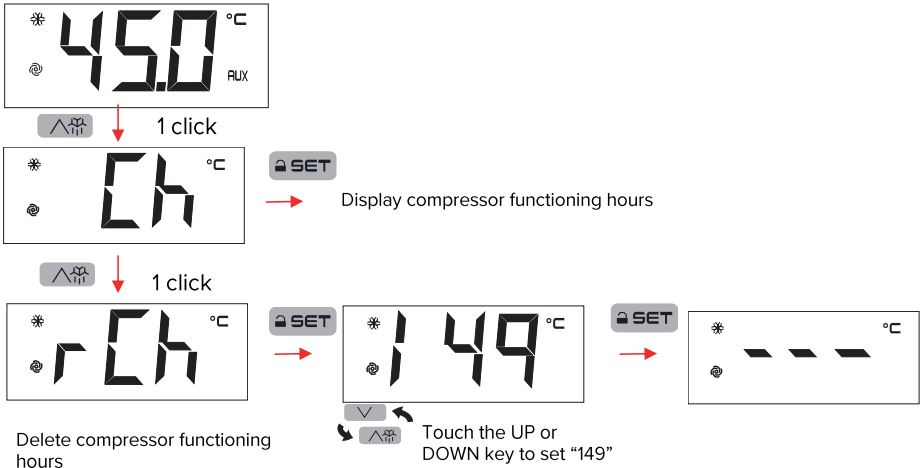

## Antilegionella

The antilegionella feature reduces the risk of development of bacteria in the tank.

The system performs a thermal shock disinfection to avoid any risk conditions that might cause the development of bacteria. The disinfection is made automatically once a month, reaching a temperature of 65 °C.

Antilegionella can be disabled or enabled in the installer menu.

## Alarms

Alarms	Meaning
Pr1	Water temperature probe alarm. Check the temperature probe integrity and the electrical connection
Pr2	Water temperature probe alarm. Check the temperature probe integrity and the electrical connection
Pr3	Evaporator temperature probe alarm. Check the temperature probe integrity and the electrical connection
AL	Low temperature alarm
AH	High temperature alarm
LHP	Low pressure switch alarm / Device blocked Switch the device off and on
HP	High pressure switch alarm Switch the device off and on
FIL	Compressor maintenance alarm By touching any key, you delete the compressor functioning hours
UtL	Evaporator failure alarm Switch the device off and on

# Maintenance of the EcoHeat

## General

This chapter describes the simplest maintenance work on the EcoHeat Unit itself.

Servicing should only be carried out by competent installers and any spare parts used must be purchased from JOULE.



**Never bypass any safety devices or operate the unit without them being fully operational**

## Draining

Switch the electrical power off (important to avoid damage to element). Isolate boiler from the unit. Turn off the cold water supply valve. Open hot water tap. Open the drain valve. The unit will drain.



**Water drained off may be very hot!**

## Annual Maintenance

The water heaters require annual servicing in order to ensure safe working and optimum performance. It is essential that the following checks are performed by a competent installer on an annual basis. This is commonly done at the same time as the annual boiler service.

- Twist the cap of the expansion relief valve on the inlet control set and allow water to flow for 5 seconds. Release and make sure it resets correctly.
- Repeat with the pressure / temperature relief valve. In both cases check that the discharge pipework is carrying the water away adequately. If not, check for blockages etc. and clear.
- Check that any immersion heaters fitted are working correctly and that they are controlling the water at a temperature between 55°C and 65°C.
- Check the pressure in the expansion vessel is charged to 3 bar. Turn off the water supply to the unit and open a hot tap first. The air valve on expansion vessel is a Schrader (car tyre) type.
- Air, CO<sub>2</sub> or Nitrogen may be used to charge the expansion vessel. Unscrew the head on the inlet control set and clean the mesh filter within.

The Service Log Book supplied with this unit should be updated at each service.



**Your guarantee may be void if you cannot produce proof of annual servicing immersion heater replacement.**

## Immersion Heater Replacement

If the thermal cut out on the Immersion heater operates contact a competent installer. If the thermal cut out fault occurs again the immersion will need to be replaced.

Prior to installing the replacement Immersion, ensure the o-ring is correctly positioned on the head of the Immersion and lubricate the threads before fitting.

Thread the Immersion by hand until it is hand tight and then tighten gently to allow the o-ring to create a water tight seal.

## Inspection

Where internal inspection of the unit is required an endoscope can be used. Inspection can be carried out by draining down the unit and removing a component that is fitted to a wet connection in the unit.

## Safety Valve Checks

Water discharges from either the temperature/pressure relief valve or the expansion relief valve indicates a problem.

- Check your discharge pipework is free from debris and is carrying water away to waste effectively.
- Next hold both of these safety valves open, allowing as much water as possible to flow through the tundish.
- Release the valves and check that they reseat correctly.



**Completion of the Benchmark Checklist on pages 46-47 must be adhered to by the installer**

# Spare Parts

ONLY the replacement of the filter may be done by the user themselves, any other work on the EcoHeat heat pump must be completed by a technician specially trained by Joule.

Always replace parts of the EcoHeat with original EcoHeat parts from Joule. The use of third-party parts may cause the product to malfunction or create a hazard. Disregarding of these points may have a negative effect on the EcoHeat warranty and void Joules statutory responsibilities.

## Spare parts list

The design and operation of an exhaust air heat pump system has a direct link to its output and efficiency. Consideration should be given to heating and ventilation at an early stage in any project as the system requires to be integrated with construction and building project process.

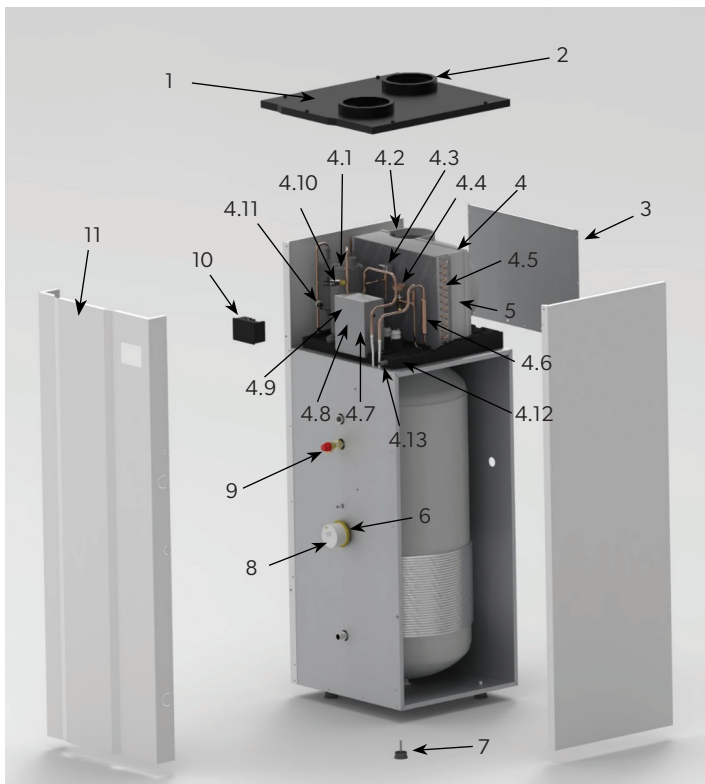

Ref.	Joule item No.	Description
1		TOP COVER / AIR CONNECTIONS Ø150-160-200mm
2		SUCTION FILTER
3		BACK COVER
4		EVAPORATOR UNIT
4.1		COMPRESSOR
4.2		VENTILATION KIT
4.3		SOLENOID VALVE / COIL
4.4		EXPANSION VALVE
4.5		EVAPORATOR
4.6		CUPPER FILTER
4.7		CONTACTOR 25A
4.8		MECHANICAL THERMOSTAT
4.9		ELECTRICAL CONNECTIONS STRIP
4.10		HIGH PRESSURE SWITCH
4.11		LOW PRESSURE SWITCH
4.12		CONDENSATE TRAY
4.13		DRAIN FITTING
5		ROOM PROBE
6		HOT WATER PROBE
7		ANTIVIBRATION FEET
8		ELECTRICAL HEATER
9		SAFETY VALVE
10		DIGITAL CONTROLLER
11		FRONT COVER
12		LATERAL SIDE

## Safety notes

- Always securely disconnect the power for the EcoHeat before installing, opening or performing maintenance on the product.
- Ensure that the unit could not be accidentally switched on while any maintenance procedure is underway.
- Do not use this appliance for functions other than those described in this booklet.
- Never touch the appliance with wet or damp hands, or when barefoot.
- Do not store inflammable products in the neighbourhood of the unit.
- The unit is only suitable for 230 VAC/50Hz electric mains.
- Never modify the fan or electronics by yourself.

## Air Filter - 12 Months

The replacement of the Air filter is required to take place every 12 months after installation.

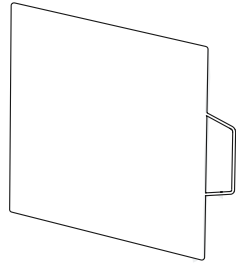

## Air Distribution System - 2 Years

Inspection of duct work where possible.

Check air flow rate on all ceiling extract valves.

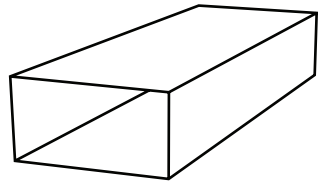

## Accessing Internal Aspects of the EcoHeat

Periodically the EcoHeat's drip tray will need to be cleaned. This necessitates the opening of the EcoHeat unit to access its internals. This also allows the perfect opportunity to inspect and clean the other parts of the unit that may require it.

### Opening of EcoHeat procedure:

Remove the top cover plate. The plate is held on with 4 screws. The front cover can now pull directly out



# Warranty

## Joule EcoHeat Warranty T&C's

### Registrations

It is a condition of the warranty that the System Recording and Installation Checklist is completed and left in the Handover Pack. The online Warranty Application is registered for using the Joule commissioning App during the Installation process carried out by the Joule trained and qualified installer.

### Terms & Conditions

The EcoHeat system can only be commissioned by a qualified installer. This installer must have been trained by Joule specifically in the installation of the Joule EcoHeat system. Systems installed by an installer that does not meet these qualifications will have no warranty.

The unit must be serviced annually. Invoices for servicing may be requested to prove that the unit has been serviced annually.

### Warranty

Joule hereby guarantees to you, the purchaser of the hot water heat pump system to which this warranty is attached that the product will be free from defects in materials and workmanship, for a period of three (3) years from the date of purchase or two (2) years from Practical Completion (PC), whichever is soonest; provided that the product is installed in accordance with:

- a The accompanying EcoHeat Installation Manual;
- b Any special written design or installation guidelines provided by Joule;
- c All applicable laws, rules, regulations, codes and standards applying in the territory in which the product is installed, including without limitation, all applicable local building and electrical codes.

This warranty is transferable to subsequent owners of the product.

### Exclusions

If Joule finds the product to be defective as a sole result of defects in material or workmanship - then, during the Warranty Period, upon receipt of due notice from you and subject to the terms of this Warranty.

Joule shall:

Repair the product

Refund the cost for repair of the Product, as well as labour and materials required to repair the Product

Replace the Product, or parts thereof; or

Refund part or all the original purchase price.

The warranty does not cover, and Joule shall not be held liable for any of the following damages:

- damages caused, wholly or partially, due to abuse, misuse, negligence, application and/or maintenance not as recommended by Joule
- damages to the product caused by workers, visitors on the job site, or post- installation work;
- damages caused by accident, natural disaster (such as fire, floods, lightning, etc.) force majeure, sabotage, or any unforeseen circumstances;
- special, indirect, incidental, secondary, consequential or any other damages of any nature arising out of ownership or use of the product including inconvenience or loss of use.

Joule refuses any warranty not provided herein, including any implied warranty of the merchant ability or implied warranty of fitness for a particular purpose. There are no warranties, which extend beyond the face of this document. No agent or representative of Joule has any authority to extend or modify this warranty unless such extension or modification is made in writing by a corporate officer.

# Warranty

## Joule Cyclone Warranty

### Terms & Conditions

The JOULE stainless steel vessel carries a fully transferable 25-year guarantee against faulty materials or manufacture provided that:

- It has been installed in the United Kingdom or the Republic of Ireland as per the instructions provided in the installation manual provided with the tank and in accordance with all of the relevant standards, regulations and codes of practice in force at the time;
- It has not been modified in any way, other than by JOULE;
- It has not been misused, tampered with or subjected to neglect;
- The system is fed from the public mains water supply;
- It has only been used for the storage of potable water;
- It has not been subjected to frost damage.
- The unit has been serviced annually;
- The Service Log Book has been completed after each annual service;

### Exclusions

The guarantee does not cover tanks affected by the following:

- The effects of scale build up on the tank;
- Any labour charges associated with replacing the unit or its parts;
- Any consequential losses caused by the failure or malfunction of the unit.

Please note that invoices for servicing may be requested to prove that the unit has been serviced annually.

### Unvented Kit & Other Components.

The expansion vessel and cold water controls supplied with JOULE models carry a 2-year guarantee.

All other components that are fitted to, or supplied, with the unit carry a 2-year guarantee.

The Joule 25-year warranty covers Joule tank installed in domestic properties against corrosion for a period of 25 years from the Practical Completion (PC).

All other components, including valves, expansion vessels, immersion heaters, fittings and controls are covered by a 2-year warranty from the date of Practical Completion (PC) which includes one year's parts and labour and one year parts only.

### Warning To the User

- Do not remove or adjust any part of this unvented water heater.
- If the unvented water heater develops fault, such as a flow of water from the discharge pipe switch the heater off.
- In all cases contact a competent installer.
- The Benchmark Checklist at the end of the manual must be filled in at annual service.

## Warning To the Installer

- Read the installation instructions before commencing.
- Unvented water heaters are a controlled service as defined in the latest edition of the Building Regulations and should only be fitted by a competent installer.
- The installation is subject to approval.
- You must notify the local authority of intention to install.
- After installation the instructions manual must be completed and left with the householder.
- Use only manufacturer's recommended replacement parts.

# Benchmark Checklist

## GAS BOILER SYSTEM COMMISSIONING CHECKLIST

This Commissioning Checklist is to be completed in full by the competent person who commissioned the storage system as a means of demonstrating compliance with the appropriate Building Regulations and then handed to the customer to keep for future reference. Failure to install and commission this equipment to the manufacturer's instructions may invalidate the warranty but does not affect statutory rights.

Customer Name \_\_\_\_\_ Telephone Number \_\_\_\_\_  
 Address \_\_\_\_\_  
 Cylinder Make and Model \_\_\_\_\_  
 Cylinder Serial Number \_\_\_\_\_  
 Commissioned by (*print name*) \_\_\_\_\_ Registered Operative ID Number \_\_\_\_\_  
 Company Name \_\_\_\_\_ Telephone Number \_\_\_\_\_  
 Company Address \_\_\_\_\_  
 \_\_\_\_\_ Commissioning Date \_\_\_\_\_  
**To be completed by the customer on receipt of a Building Regulations Compliance Certificate\*:**  
 Building Regulations Notification Number (*if applicable*) \_\_\_\_\_

### ALL SYSTEMS PRIMARY SETTINGS (*indirect heating only*)

Is the primary circuit a sealed or open vented system? Sealed  Open   
 What in the maximum primary flow temperature? \_\_\_\_\_ °C

### ALL SYSTEMS

What is the incoming static cold water pressure at the inlet to the system? \_\_\_\_\_ bar  
 Has a strainer been cleaned of installation debris (if fitted)? Yes  No   
 Is the installation in a hard water area (above 200oom)? Yes  No   
 If yes, has a water scale reducer been fitted? Yes  No   
 What type of scale reducer has been fitted? \_\_\_\_\_  
 What is the hot water thermostat set temperature? \_\_\_\_\_ °C  
 What is the maximum hot water flow rate at set thermostat temperature (measured at high flow outlet)? \_\_\_\_\_ l/min  
 Time and temperature controls have been fitted in compliance with Part L of the Building Regulations? Yes   
 Type of control system (if applicable) Y Plan  S Plan  Other   
 Is the cylinder solar (or other renewable) compatible? Yes  No   
 What is the hot water temperature at the nearest outlet? \_\_\_\_\_ °C  
 All appropriate pipes have been insulated up to 1 metre or the point where they become concealed Yes

### UNVENTED SYSTEMS ONLY

Where is the pressure reducing valve situated (if fitted)?

What is the pressure reducing valve setting? bar

Has a combined temperature and pressure relief valve and expansion valve been fitted and discharge tested? Yes  No

The tundish and discharge pipework have been connected and terminated to Part G of the Building Regulations

Are all energy sources fitted with a cut out device? Yes  No

Has the expansion vessel or internal air space been checked? Yes  No

### THERMAL STORES ONLY

What store temperature is achievable?

°C

What is the maximum primary flow temperature?

°C

### ALL INSTALLATIONS

The hot water system complies with the appropriate Building Regulations

The system has been installed and commissioned in accordance with the manufacturer's instructions Yes

The system controls have been demonstrated to and understood by the customer

The manufacturer's literature, including Benchmark Checklist and Service Record, has been explained and left with the customer Yes

Commissioning Engineer's Signature

Customer's Signature

*(To confirm satisfactory demonstration and receipt of manufacturer's literature)*

\*All installations in England and Wales must be notified to Local Authority Building Control (LABC) either directly or through a Competent Persons Scheme. A Building Regulations Compliance Certificate will then be issued to the customer.



# Service Record

It is recommended that your hot water system is serviced regularly and that the appropriate Service Record's completed.

## Service Provider

Before completing the appropriate Service Record below, please ensure you have carried out the service as described in the manufacturer's instructions.

<b>Service 1</b>	Date .....
Engineer Name	
Company Name	
Telephone No	.....
Comments	.....
.....	.....
.....	.....
.....	.....
Signature	.....

<b>Service 1</b>	Date .....
Engineer Name	
Company Name	
Telephone No	.....
Comments	.....
.....	.....
.....	.....
.....	.....
Signature	.....

<b>Service 1</b>	Date .....
Engineer Name	
Company Name	
Telephone No	.....
Comments	.....
.....	.....
.....	.....
.....	.....
Signature	.....

<b>Service 1</b>	Date .....
Engineer Name	
Company Name	
Telephone No	.....
Comments	.....
.....	.....
.....	.....
.....	.....
Signature	.....

<b>Service 1</b>	Date .....
Engineer Name	
Company Name	
Telephone No	.....
Comments	.....
.....	.....
.....	.....
.....	.....
Signature	.....

<b>Service 1</b>	Date .....
Engineer Name	
Company Name	
Telephone No	.....
Comments	.....
.....	.....
.....	.....
.....	.....
Signature	.....

<b>Service 1</b>	Date .....
Engineer Name	
Company Name	
Telephone No	.....
Comments	.....
.....	.....
.....	.....
.....	.....
Signature	.....

<b>Service 1</b>	Date .....
Engineer Name	
Company Name	
Telephone No	.....
Comments	.....
.....	.....
.....	.....
.....	.....
Signature	.....

<b>Service 1</b>	Date .....
Engineer Name	
Company Name	
Telephone No	.....
Comments	.....
.....	.....
.....	.....
.....	.....
Signature	.....

<b>Service 1</b>	Date .....
Engineer Name	
Company Name	
Telephone No	.....
Comments	.....
.....	.....
.....	.....
.....	.....
Signature	.....

# Service Record

**Service 1** Date .....

Engineer Name  
Company Name  
Telephone No .....  
Comments .....  
.....  
.....  
Signature .....

**Service 1** Date .....

Engineer Name  
Company Name  
Telephone No .....  
Comments .....  
.....  
.....  
Signature .....

**Service 1** Date .....

Engineer Name  
Company Name  
Telephone No .....  
Comments .....  
.....  
.....  
Signature .....

**Service 1** Date .....

Engineer Name  
Company Name  
Telephone No .....  
Comments .....  
.....  
.....  
Signature .....

**Service 1** Date .....

Engineer Name  
Company Name  
Telephone No .....  
Comments .....  
.....  
.....  
Signature .....

**Service 1** Date .....

Engineer Name  
Company Name  
Telephone No .....  
Comments .....  
.....  
.....  
Signature .....

**Service 1** Date .....

Engineer Name  
Company Name  
Telephone No .....  
Comments .....  
.....  
.....  
Signature .....

**Service 1** Date .....

Engineer Name  
Company Name  
Telephone No .....  
Comments .....  
.....  
.....  
Signature .....

**Service 1** Date .....

Engineer Name  
Company Name  
Telephone No .....  
Comments .....  
.....  
.....  
Signature .....

**Service 1** Date .....

Engineer Name  
Company Name  
Telephone No .....  
Comments .....  
.....  
.....  
Signature .....





# Notes

---

---

---

---

---

---

---

---

---

---

---

---

---

---

---

---

---

---

---

---

---

---

---

---

---

---

---

---

---

---

## JOULE IE

Unit 407 NW Business Park,  
Cappagh Road, Ballycoolin,  
Blanchardstown, Dublin

tel +353 (1) 623 7080  
fax +353 (1) 626 9337  
mail [info@joule.ie](mailto:info@joule.ie)  
web [www.joule.ie](http://www.joule.ie)

## JOULE UK

Unit 1 & Unit 3,  
Lefffield Park, Park Road, West Yorkshire,  
WF8 4PS, United Kingdom

tel +44 (0) 330 808 8488  
fax +44 (0) 1513 568 336  
mail [info@jouleuk.co.uk](mailto:info@jouleuk.co.uk)  
web [www.jouleuk.co.uk](http://www.jouleuk.co.uk)

## JOULE PL

Strzegomska 55D,  
53-611 Wrocław, Polska

tel +48 (0) 128811171  
fax +48 (0) 814709046  
mail [biuro@joule-pl.pl](mailto:biuro@joule-pl.pl)  
web [www.joule-pl.pl](http://www.joule-pl.pl)