

08

joule
Manufacturing Excellence

Direct, Indirect & Solar Unvented Cylinder Installation & Maintenance Manual



**REGISTER THIS PRODUCT
ONLINE WITHIN 28 DAYS OF
COMMISSIONING**

UNITED KINGDOM / IRELAND



<https://joule.ie/register-products/>



JL-CYDID-INS-08-01

Warranty Card

Please register your product online

 **MUST BE COMPLETED AND THEN REGISTERED ONLINE TO COMPLETE WARRANTY**

Homeowner Name	<input type="text"/>	Installer Name	<input type="text"/>
Address	<input type="text"/>	Address	<input type="text"/>
Contact Tel.	<input type="text"/>	Contact Tel.	<input type="text"/>
Contact Email	<input type="text"/>	Contact Email	<input type="text"/>

Product	Product Installed	Serial Number	Installation Date
Cylinder	<input type="radio"/>		Located on cylinder badge
Solar Thermal	<input type="radio"/>		Take from solar controller
Solar PV	<input type="radio"/>		Ser. No. from String / Micro Inverter
Air Source Heat Pump	<input type="radio"/>		Located on external heat pump badge
Integrated Heat Pump and Cylinder	<input type="radio"/>		Located on cylinder badge
Underfloor Heating	<input type="radio"/>		Project ref. on supplied schematic
Direct Gas Fire Cylinder	<input type="radio"/>		Located on cylinder badge
Was a Pre-Plumbed cylinder installed too?	<input type="radio"/>	If installed, please fill out the Heat Pump Commissioning Sheet too	

Joule™ Advance Installer

I accept the terms and conditions in the installation manual

Joule™ Product Warranty Terms & Conditions

Joule™ Cyclone

The **Joule™ Cyclone** stainless steel vessel carries a fully transferable 25-year guarantee against faulty materials or manufacture provided that:

- It has been installed in the United Kingdom or the Republic of Ireland as per the instructions provided in the installation manual provided with the cylinder and in accordance with all of the relevant standards, regulations and codes of practice in force at the time.
- It has not been modified in any way, other than by Joule™
- It has not been misused, tampered with or subjected to neglect.
- The system is fed from the public mains water supply.
- It has only been used for the storage of potable water.
- It has not been subjected to frost damage.
- The unit has been serviced annually.
- The Service Log Book has been completed after each annual service.
- The warranty card is filled in and a copy is sent by email to warranty@joule.ie

Exclusions

The guarantee does not cover cylinders affected by the following;

- The effects of scale build up on the cylinder.
- Any labour charges associated with replacing the unit or its parts.
- Any consequential losses caused by the failure or malfunction of the unit.

Please note that invoices for servicing may be requested to prove that the unit has been serviced annually.

Unvented Kit & Other Components

The Joule™ 25-year warranty covers Joule™ cylinders installed in domestic properties against corrosion for a period of 25 years from the date of purchase. All other components, including valves, expansion vessels, immersion heaters, fittings and controls are covered by a two year warranty from the date of purchase of the Joule™ product which includes one year's parts and labour and one year parts only.

Joule™ Wellmaster

The Joule™ Wellmaster stainless steel vessel carries a fully transferable 10-year guarantee against faulty materials or manufacture provided that:

- It has been installed in the United Kingdom or the Republic of Ireland as per the instructions provided in the installation manual provided with the cylinder and in accordance with all of the relevant standards, regulations and codes of practice in force at the time.
- It has not been modified in any way, other than by Joule™.
- It has not been misused, tampered with or subjected to neglect.
- It has only been used for the storage of potable water.
- The sacrificial anode is removed for inspection within 3 months of the cylinder installation. If there are signs of corrosion on the anode it must be replaced.
- A replacement schedule for the anode must be put in place based on the findings of the initial 3 month inspection.
- Maximum interval between anode inspections is 12 months.
- The warranty card is filled in and a copy is sent by email to warranty@joule.ie

Exclusions

The guarantee does not cover cylinders affected by the following;

- Wellmaster cylinders where the anode has not been routinely maintained.
- Any labour charges associated with replacing the unit or its parts.
- Any consequential losses caused by the failure or malfunction of the unit.

Please note that invoices for servicing may be requested to prove that the unit has been serviced annually.

Joule™ fully endorse the Benchmark scheme and the code of practice can be obtained from www.centralheating.co.uk

Warning To The User

- Do not remove or adjust any part of this unvented water heater.
- If the unvented water heater develops fault, such as a flow of water from the discharge pipe switch the heater off.
- In all cases contact a competent installer.
- The Benchmark Log Book at the end of the manual must be filled in at annual service.

Warning To The Installer

- Read the installation instructions before commencing.
- Unvented water heaters are a controlled service as defined in the latest edition of the Building Regulations and should only be fitted by a competent installer.
- The installation is subject to approval.
- You must notify the local authority of intention to install.
- After installation the instructions manual must be completed and left with the householder.
- Use only manufacturer's recommended replacement parts.

Installed by

Installer Name	<input type="text"/>
Address	<input type="text"/>
Contact Tel.	<input type="text"/>
Completion Date	<input type="text"/>

Table Of Contents

6	Introduction
10	General Requirements
14	Unvented Kit Components
15	Unvented Kit Checklist
16	ErP Product Fiche
17	Technical Data
18	Indirect Vertical Technical Specification
20	Direct Vertical Technical Specification
22	Solar Vertical Technical Specification
24	Plumbing G3 Unvented Kit
25	Testing
26	Smart Control Immersion Setup
27	Immersion Testing
30	Un-Plumbed Cylinder Schematic S-Plan
32	Un-Plumbed Cylinder Schematic Y-Plan
34	Electronic Controls
35	Discharge Arrangement
38	Commissioning
39	Maintenance
41	Taking The Cylinder Out Of Use
42	Troubleshooting
44	Benchmark Checklist
46	Service Record
47	Notes

NEW

Introduction

The instructions are an integral part of the appliance and must be given to the end user on completion of the installation in order to comply with the current regulation.

It is important to carefully read the manual to understand all the information to enable safe installation, use and servicing. These instructions consist of details for installation, servicing, fault finding and replacement of parts for the cylinder purchased.

Joule™ will not accept any liability in the event of damage for not complying with the guidance in this instruction manual.

The instructions for this installation manual apply to the range of **Joule™ Cyclone Unvented Cylinders**.

Safety is paramount when installing unvented hot water systems and the following instructions must be adhered to:

- Only certified competent installers can install, commission and service the equipment supplied.
- The cylinder must be used for potable hot water only. Any other applications will be considered incorrect use and Joule™ will not be held liable for any losses resulting from such use.
- All installation and maintenance instructions must be observed to ensure the correct operation of the equipment.
- The electric immersion must not be switched on unless the cylinder is completely full of water.
- Domestic hot water may be stored at temperatures exceeding 60°C. Preventative measures should be put in place to negate the possibility of scalding.
- A maintenance schedule should be put in place with a competent person to service the equipment annually to comply with the warranty conditions.
- When servicing the system the mains supply to the cylinder should be isolated.
- Only genuine spare parts should be used. A full list of items with relevant codes can be found on page 14.

The installation must be carried out by a person competent to install unvented hot water systems. The installation must be carried out in accordance with the following recommendations:

All current Building Regulations issued by the Department of the Environment, i.e. Building Regulation G3 (England and Wales), Technical Standard P3 (Scotland) or Building Regulation P5 (Northern Ireland) and the Water Fitting Regulations (England and Wales) or Water Byelaws (Scotland). The installation should also be in accordance with the following British Standard Codes of Practice:

BS 5449:1990 Forced circulation hot water systems

BS 5546:2000 Installation of hot water supplies for domestic purposes

BS 5918:1989 Solar heating systems for domestic hot water

BS 6700:2006 Design, installation, testing and maintenance of services supplying water.

Failure to install this appliance correctly could lead to prosecution and will invalidate the guarantee.

It is in your own interest and that of safety to ensure that the law is complied with.

Handling

Care must be taken when transporting, storing and installing the equipment:

- At least two people should lift the cylinder to prevent injuries.
- The cylinder must be stored in a dry area and must never be dropped during handling.
- Packaging should only be removed at the installation location.
- The cylinder must be installed on a level floor with the required load bearing capability. Installation, servicing, maintenance and repair must be carried out by a competent person.
- All electrical wiring must be carried out by a qualified electrician and be installed in accordance with current I.E.E Wiring Regulations.
- A lack of safety devices can lead to potentially fatal injuries, all necessary safety devices must be installed correctly in the system. The use of an electric immersion may lead to the build up of electrical potential in the water. This can in turn cause corrosion of the immersion. To prevent this, ensure the immersion heater, and the hot and cold pipework are correctly bonded and connected to the earth line.
- If plastic pipes are used they must be approved temperature resistant to 95°C at a pressure of 10bar.

A thermostatic mixer should be installed in the system to prevent the risk of scalding. If there are leaks found in the system, shut off the cold water stop valve from the main supply and contact a competent person immediately. Also ensure to isolate the power going to any immersions fitted to the cylinder

What Is Benchmark?

Benchmark places responsibilities on both manufacturers and installers. The purpose is to ensure that customers are provided with the correct equipment for their needs, that it is installed, commissioned and serviced in accordance with the manufacturer's instructions by competent persons and that it meets the requirements of the appropriate Building Regulations.

The Benchmark Checklist can be used to demonstrate compliance with Building Regulations and should be provided to the customer for future reference. Installers are required to carry out installation, commissioning and servicing work in accordance with the Benchmark Code of Practice which is available from the Heating and Hot Water Industry Council who manage and promote the scheme. Visit www.centralheating.co.uk

HWA Charter Member

Joule™ are proud to be a charter member of the the Hot Water Association (HWA), that has been formed through the union of the two UK industry trade bodies, WMA (Water Heater Manufacturers Association) and MODUS (Manufacturers Of Domestic Unvented Systems).

The objectives of the HWA are "To be recognised as the leading body in domestic hot water storage and, through cooperation and partnerships, to support, drive and promote the sustained growth and improvement of standards within the entire domestic hot water industry".

The HWA operate a Charter that all members of the association observe.

The HWA Charter Statement requires that all members adhere to the following:

- To supply fit for purpose products clearly and honestly described
- To supply products that meet or exceed appropriate standards and Building And Water Regulations
- To provide pre and post technical support

Introduction

- To provide clear and concise warranty details to customers

Water Supply

The performance of any unvented system is only as good as the mains water supply available. To this effect the maximum possible water demand should be assessed, with the knowledge that the mains supplies both hot and cold services simultaneously. The water heater itself operates at a pressure of 3bar, controlled by the inlet control set, and is capable of delivering over 50 litres per minute. The high quality inlet control set has been designed to make the most of the low rates available.

The water supply should be checked to ensure it can meet these requirements. If necessary, consult the local water authority regarding the likely pressure and flow rate availability. Consideration should be given to upgrading existing 1/2" (15mm) cold mains pipework to a larger size if the recommended minimum pressure / flow rate is not being achieved. Joule™ recommend that primary pipework used has a minimum diameter of 22mm to ensure low pressure loss.



A high static (no flow) mains pressure is no guarantee of good flow availability. In a domestic installation 1.5bar and 25ltr/min should be regarded as the minimum. The maximum mains pressure that the inlet control set can cope with is 10bar.

Change Of Water Supply

The changing or alternating from one water supply to another can have a detrimental effect on the operation and/or life expectation of the water heater storage cylinder, pressure temperature relief valve and heating unit.

Where there is a changeover from one water supply to another, e.g. a rainwater tank supply, bore water supply, desalinated water supply, public reticulated water supply or water brought in from another supply, then water chemistry information should be sought from the supplier or it should be tested to ensure the water supply meets the requirements given in these guidelines for the Joule™ warranty to apply.

Water Chemistry

This water heater must be installed in accordance with this advice to be covered by the Joule™ warranty. This water heater is manufactured to suit the water conditions of most public reticulated water supplies. However, there are some known water chemistries which can have detrimental effects on the water heater and its operation and/or life expectancy. If you are unsure of your water chemistry, you may be able to obtain information from your local water supply authority.

Water Chemistry Levels Affecting Warranty

The Joule™ warranty of this water heater will not cover resultant faults on components including the storage cylinder where water stored in the storage cylinder exceeds at any time any of the following levels:

Components	Maximum Permitted Levels
Total Dissolved Solids	600 mg/litre
Total Hardness	200 mg/litre
Chloride	300 mg/litre
Magnesium	10 mg/litre
Calcium	20 mg/litre
Sodium	150 mg/litre
Iron	1 mg/litre
Maximum pH	9.5
Minimum pH	6.5

Total Dissolved Solids (TDS)

Some water analysis reports may state the conductivity of the water rather than the level of total dissolved solids. Conductivity, measured in microsiemens per centimetre ($\mu\text{S}/\text{cm}$), is directly proportional to the TDS content of the water. TDS, in mg/L, is approximately 70% of the conductivity in $\mu\text{S}/\text{cm}$. The Joule™ warranty will not cover resultant faults to the storage cylinder if this water heater is connected at anytime to a water supply where the TDS content of the water exceeds 600 mg/L. 16 In locations where TDS approaches 600 mg/L, e.g. due to sediment, we strongly recommend fitting an appropriate filter to ensure water entering or in the water heater does not exceed this level at any time i.e. due to sediment build up.

Features Of The Unvented Cylinder

- Made from Duplex Stainless Steel for excellent corrosion resistance.
- Strong rust-proofed steel case.
- Insulation is by means of an approved CFC/HCFC free polyurethane foam with an ozone depletion factor of zero.
- Available in a variety of sizes to suit - 100L, 125L, 150L, 170L, 200L, 250L, 300L, 400L and 500 litres.
- All models including Solar models are available in Twin or Triple versions supplied complete with all the necessary safety and control devices needed to connect to cold water mains
- All safety and control devices are pre-set.
- High quality controls selected that combine high flow rate performance with minimum pressure drop which gives fantastic performance in all areas, with great improvements in areas with poor water pressure.

General Requirements

Wellmaster Cylinders

Only Joule™ Wellmaster cylinders may be installed on a well, private water scheme or any water source that does not come from the public mains.

Water supplied to the cylinder must conform to the water chemistry table on the previous page. A descaler on the cold water feed may be used if required.



If any of the water parameters are higher than set out in the table including total hardness regardless of whether or not it is fed from a main water connection a Joule™ Wellmaster cylinder must be used.

If any of the water parameters are higher than set out in the table including Total Hardness regardless of whether or not it is fed from a main water connection a Joule™ Wellmaster cylinder must be used.

Siting The Unit

This unit can supply outlets above it or at some distance from it but any outlets above the unit will reduce the available outlet pressure by 0.1 bar for every 1m of height difference. The maximum length of the “dead leg” should be as stated in the Water Supply (Water Fittings) Regulations 1999 G18.7, in particular to the area of most frequent use.

Particular attention is needed if siting in a garage or outbuilding as the unit should be protected from frost. All exposed pipework must be insulated. The unit must be installed **upright** on a base capable of supporting its weight when full (please see the technical specification section for weights).

Sufficient access to allow maintenance of the valves should be considered. In addition the immersion heaters are 400mm in length and this distance should be considered to allow withdrawal for servicing if required. The discharge pipework from the safety valves should fall continuously and terminate safely.

Negative pressure may form in cylinders installed very high in a building. To counteract this, an anti-vacuum valve can be installed to prevent damage to the cylinder. The anti-vacuum valve ensures pressure compensation as a result of air flowing into the cylinder.

Connecting To The Cylinder

All of the pipework connections on the cylinder are compression connection and female threaded. Upon filling and commissioning, ensure all connections are completely watertight.



No control or isolation valve should be fitted between the expansion relief valve and the storage cylinder. The relief valve connections should not be used for any other purpose.

Cold Mains Pipework

Run the cold main through the building to the place where it is to be installed. Take care not to run the cold pipe near hot water or heating pipe work so that the heat pick-up is minimized. Identify the cold water supply pipe and fit an isolating valve (not supplied). A 22mm BS1010 stopcock can typically be used but a 22mm quarter turn full bore valve would be better as it does not restrict the flow as much. Do not use "screwdriver slot" or similar valves.

Make the connection to the cold feed of the cylinder and incorporate a drain valve. Position the inlet control just **above** the Temperature & Pressure Relief Valve (TPRV) mounted on the side of the cylinder. This ensures that the cylinder does not have to be drained down in order to service the inlet control set. Ensure that the arrow points in the direction of the water flow. Select a suitable position for the expansion vessel. Mount it to the wall using the bracket provided.

Balanced Cold Connection

If there are to be showers, bidets or monobloc taps in the installation then a balanced cold supply is necessary. There is a 22mm balanced connection on the inlet control set.

Fitting The Inlet Control Group

Excess pressure can lead to the cylinder bursting. The inlet control set supplied has an expansion relief valve with a 15mm connection to allow it to be connected to the tundish. Make sure that there is sufficient space for future maintenance and also for connection of the discharge pipe for the expansion relief valve.

It is essential that this connection is not covered or closed. The hot water expansion vessel should be hard fixed into pipework and insulated.

Hot Water Pipework

Run the first part of the hot water distribution pipework in 22mm. This can be reduced to 15mm and 10mm as appropriate for the type of tap etc. Your aim should be to reduce the volume of the hot draw-off pipework to a practical minimum so that the time taken for the hot water is as quick as possible.

Do not use monobloc mixer tap or showers if the balanced cold connection is not provided. Outlets of this type can back pressurise the unit and result in discharge.

Expansion Vessel

The expansion vessel receives the increased water volume when expansion takes place as the system heats up and it maintains a positive pressure in the system. The expansion vessel contains a flexible diaphragm, which is initially charged on one side with nitrogen, but can be topped up with air when required.

Select a suitable position for the expansion vessel. Mount it to the wall using the bracket provided (0-24L only, 35L and above are floor standing) and hard fix into pipework and insulate. Ensure that the top of the vessel is accessible for servicing. The pipe connecting the expansion vessel to the system should have a diameter of not less than 15mm and must not contain any restrictions.

General Requirements

Prior to connecting the expansion vessel to the system the pipework should be flushed and tested. When the vessel is connected the system should be pressurised when cold. If the initial system water pressure is too high, the diaphragm will be displaced too far into the vessel. This will leave the vessel unable to accommodate the volume of expansion water. The result of this is an increase in system pressure and the safety valve will lift.

Primary Coil Connections

Connect the primary connections (Indirect only). The primary circuit must be positively pumped. Either primary connection may be used as the primary flow. Reheat times are identical either way. The primary circuit can be open vented or sealed, with up to a maximum pressure of 3.5 bar. If you seal the primary circuit an additional expansion vessel and safety valve is required.

The boiler may be Gas, Electric or Oil but must be under effective thermostatic control. Uncontrolled heat sources such as some AGA's, back boilers, solid fuel stoves, etc. are **not suitable**. Please contact our Technical department for guidance. Connect the two port zone valve (indirect only) into the primary flow pipework. The direction of flow arrow should be towards the primary flow connection.

Installing The Two Port Motorised Valve

The function of the Two Port Motorised Valve prevents the cylinder from overheating. It can be installed on either horizontal or vertical pipework. If it is mounted onto horizontal pipework the valve head must face upwards. The direction of flow is marked on the body of the valve with arrows.

Thermostatic Mixer

When installing a solar system with an unvented Joule™ Cyclone twin coil cylinder, a thermostatic mixing valve should be installed. Its function is to act as an anti scald protection. The thermostatic mixer is to be set to a temperature of between 30°C and 60°C and is supplied by the installer.

Secondary Circulation

On larger installations long pipe runs to draw-off points can cause significant volumes of water to be drawn off before an acceptable temperature can be reached. Secondary pumped circulation using a stainless steel or a bronze pump, and combined with effective time and temperature controls can overcome this problem. Where secondary return circulation is required the pipework should be run in 15mm pipe. A suitable WRAS approved stainless steel or bronze circulation pump must be used. A check valve must also be installed to prevent back flow.

On large secondary circulation systems it may be necessary to incorporate an extra expansion vessel into the circuit to accommodate the increased system water volume. Secondary circulation should be avoided on Direct electrically heated units being used on off-peak electricity tariffs. It should be noted that the use of a secondary circulation circuit can increase running costs as there will be circulation pipe losses. High levels of insulation on secondary pipework are required to keep energy losses to a minimum.

Dead Legs

The length of hot water draw off to taps and other outlets should be kept to a minimum to reduce the amount of cold water drawn off before the hot water arrives. The maximum recommended dead leg lengths are shown in the table below. Where there is more than one size of pipe on a dead leg, the equivalent length and size should be estimated. Where the dead leg length exceeds the recommended maximum, secondary circulation should be installed. It should be controlled by a time switch and incorporate a motorized valve that can prevent gravity circulation in the circuit.

Pipe Size (mm)	Maximum Length (m)
10, 12	20
15, 22	12
28	8
35 and above	3

System Noise

Noise in pipework may occur as a result of expansion of pipework over joists or where the pipe has been left touching other pipes or a part of the building structure. Care must be taken to ensure that the pipework is correctly bracketed, is not in tension or compression, and does not carry the weight of components such as a circulation pump.

Setting The Hot Water Temperature

The hot water temperature is set on the dual thermostat by the competent person during the installation. The dual thermostat should be set to 60°C. If you are heating water in the cylinder for the first time, or the time controls for the DHW zone have been off for a prolonged period of time, the cylinder may take additional time to heat up.



Inappropriate adjustments can lead to the damages in the system. If any changes are made to the cylinder, the controls, the water and power supply lines or the expansion relief components there is a risk of steam escaping or rupture to the system.

Invented Kit Components



TZ9-4.0-0000.5
TZ9-4.0-000.75



TZC-Y-0000000Z



TZC-D-000000Z



TZU-000015X22
TZU-0000 022X1



TzM-I-00022MM



TZG-3.0-0.75L
TZG-3.0-0001L



TV-P-000012L TV-P-000035L
TV-P-000019L TV-P-000050L
TV-P-000024L



TI-I-L-14-3-1

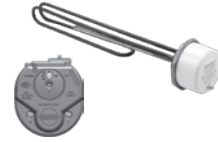

TI-S-L-14-3-1
Smart

Invented Kit Checklist

Capacity (ltr)	100	125	150	170	200	250	300	400	500
Inlet Group	TZG-3.0-0.75L								TZG-3.0-0001L
Expansion Vessel	TV-P-000019L					TV-P-000024L	TV-P-000035L	TV-P-000050L	
T&P Valve	TZ9-4.0-0000.5						TZ9-4.0-000.75		
Tundish	TZU-000015X22								TZU-0000022X1
Dual Stat	TZC-D-000000Z								
Prim. Coil 2-P Z.Valve	TZM-I-00022MM								

Direct	Indirect
Inlet Control Group	Inlet Control Group
Tundish	Tundish
T&P Valve (fitted)	T&P Valve (fitted)
3kW Immersion (fitted)	3kW Immersion (fitted)
Expansion Vessel	Expansion Vessel
	Dual Cylinder Stat
	2-port Zone Valve

ErP Product Fiche Information

Nominal Capacity (ltr)	100	125	150	170	200	250	300	400	500
Direct Vertical									
Storage volume V (ltr)	99	127	150	169	200	250	294	-	-
Mixed water at 40°C (ltr)	149	191	225	254	300	377	441	-	-
The declared load profile	L	L	L	L	L	L	XL	-	-
ErP Rating	C	C	C	C	C	C	D	-	-
Energy Efficiency (%)	39	39	38	38	38	37	37	-	-
Ann. el. consumption (kWh)	2650	2654	2715	2719	2723	2764	4508	-	-
Sound Power Level (dB)	16	16	16	16	16	16	16	-	-
Thermostat Temp. Set. (°C)	60	60	60	60	60	60	60	-	-
Daily En. Usage Qelec (kWh/24h)	12.189	12.213	12.577	12.601	12.625	12.868	20.962	-	-

Nominal Capacity (ltr)	100	125	150	170	200	250	300	400	500
Indirect & Solar Vertical									
Storage Volume V (ltr)	96	124	147	168	194	247	290	390	495
Standing Loss (kW)	44	52	55	58	78	87	92	102	115
ErP Rating	B	B	B	B	C	C	C	C	C

Technical Data

Indirect models in conformance with BS EN 12897:2016

Maximum mains water supply pressure	2.5MPa (25 bar)
Operating pressure/PRV	0.3MPa (3 bar)
Expansion vessel pressure	1.0MPa (10 bar max)
Expansion relief valve setting	0.6MPa (6 bar)
Maximum design pressure	0.4MPa (4 bar)
T&P relief valve setting	0.7MPa/90 °C (7 bar)
Primary coil operating pressure (max)	0.6MPa (6 bar)
Immersion heater rating (a.c. supply only) single phase	3kW 50/60Hz ~
Storage weights (empty and full)	See Specification Tables
Indirect coil ratings	See Specification Tables
Pressure drop across the indirect coils	See Specification Tables
Coil surface area	See Specification Tables

Indirect Vertical Technical Specification

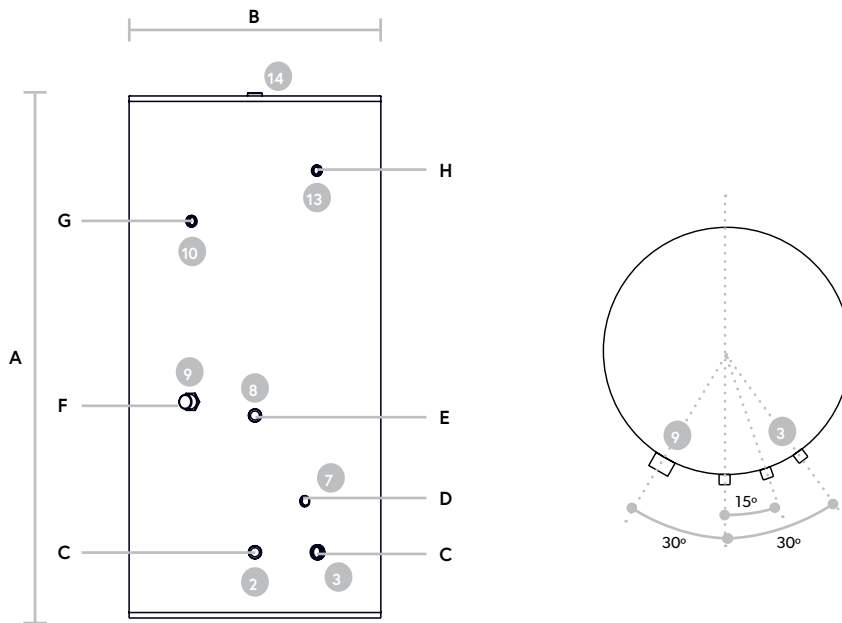

- 2 Boiler Return
- 3 Cold Water Inlet
- 7 Aquastat Pocket
- 8 Boiler Flow
- 9 Incoloy Immersion (fact. fitted)
- 10 Secondary Return
- 13 T&P Relief Valve
- 14 Hot Water Draw Off

Connection Sizes & Safety	100	125	150	170	200	250	300	400	500
Hot & Cold Conn. Ø (mm)	22	22	22	22	22	22	22	28	28
Coil Connection Ø (mm)	22	22	22	22	22	22	22	22	22
Secondary Return Ø BSP F (")	0.5	0.5	0.5	0.5	0.5	0.5	0.5	0.5	0.5
T&P Connection Ø BSP F (")	0.5	0.5	0.5	0.5	0.5	0.5	0.5	0.75	0.75
3bar	T&P Press. Set. (bar)	7	7	7	7	7	7	7	7
	Exp. Relief Set. (bar)	6	6	6	6	6	6	6	6

Dimensions	100	125	150	170	200	250	300	400	500
Cylinder Height (A, mm)	950	1030	1190	1310	1490	1815	1600	1570	1900
Cylinder Diameter (B, mm)	500	540	540	540	540	540	600	710	710
Connection Height C (mm)	188	196	196	196	196	196	218	225	225
Connection Height D (mm)	333	211	341	341	341	361	383	405	455
Connection Height E (mm)	478	511	486	486	516	586	608	675	745
Connection Height F (mm)	543	651	651	651	581	651	673	740	810
Connection Height G (mm)	628	751	786	881	981	1271	1153	1180	1440
Connection Height H (mm)	743	800	911	1031	1211	1531	1333	1280	1640

Performance	100	125	150	170	200	250	300	400	500
Heat Up Time ΔT 50°C (min)	22	23	26	27	31	37	42	52	54
1° Re-Heat time (70% dr. off) 15L/m	12	14	17	18	21	25	29	37	38
Weight Empty (kg)	27	30	34	37	41	49	56	62	89
Weight Full (kg)	152	155	184	207	241	299	356	462	589
Prim. Coil Surf. Area (m ²)	0.58	0.58	0.58	0.58	0.67	0.77	0.77	1.16	1.25
Prim. Coil Rat. @15L/m (kW, 80±2°C)	20	20	20	20	21	23	23	25	26
Pr. Coil Press. Drop @ 60L/hr (mbar)	45	45	45	45	65	76	76	88	90
Cont. Output @60°C ΔT 50°C (L/hr)	382	382	382	382	401	440	440	478	497

Direct Vertical Technical Specification

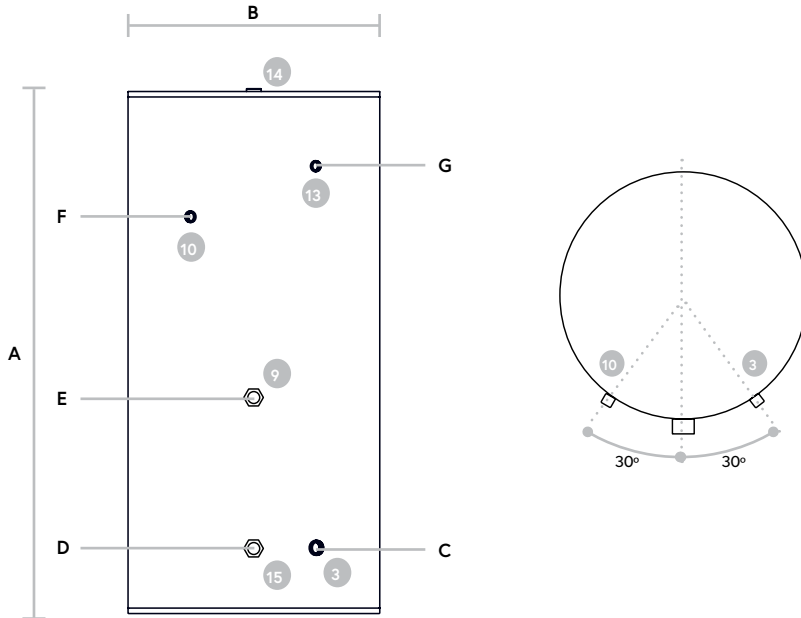

- 3 Cold Water Inlet
- 9 Incoloy Immersion (fact. fitted)
- 10 Secondary Return
- 13 T&P Relief Valve
- 14 Hot Water Draw Off
- 15 Smart Immersion (fact. fitted)

Connection Sizes & Safety		100	125	150	170	200	250	300
Hot & Cold Conn. Ø (mm)		22	22	22	22	22	22	22
Coil Connection Ø (mm)		22	22	22	22	22	22	22
Secondary Return Ø BSP F (")		0.5	0.5	0.5	0.5	0.5	0.5	0.5
T&P Connection Ø BSP F (")		0.5	0.5	0.5	0.5	0.5	0.5	0.5
3bar	T&P Press. Set. (bar)	7	7	7	7	7	7	7
	Exp. Relief Set. (bar)	6	6	6	6	6	6	6

Dimensions		100	125	150	170	200	250	300
Cylinder Height (A, mm)		950	1030	1190	1310	1490	1815	1600
Cylinder Diameter (B, mm)		500	540	540	540	540	540	600
Connection Height C (mm)		180	196	196	196	196	196	218
Connection Height D (mm)		203	211	211	211	211	211	233
Connection Height E (mm)		268	511	561	631	701	861	733
Connection Height F (mm)		628	651	768	881	981	1271	1153
Connection Height G (mm)		743	751	911	1031	1211	1531	1333

Performance		100	125	150	170	200	250	300
Quantity Of Factory Fitted Immersions		2						
Rating Of Factory Fitted Immersions (kW/V)		3/240						
Factory Fitted Immersion Type		Incoloy						
Number Of Immersion Bosses		2						
Heat Up Time ΔT 50°C	min	64	67	80	91	107	134	161
	Fact. Fitted kW	3						
Weight Empty (kg)		23	26	30	33	36	43	53
Weight Full (kg)		123	151	180	203	236	293	353
Cont. Output @60°C ΔT 50°C (L/hr)		94						

Solar Vertical Technical Specification

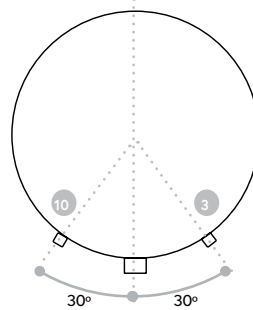
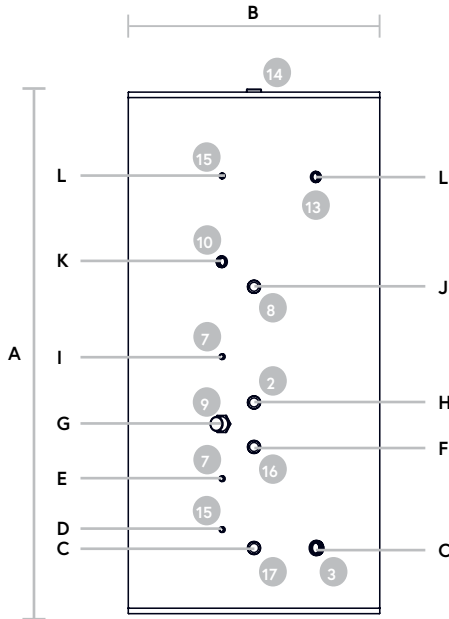

- 2 Boiler Return
- 3 Cold Water Inlet
- 7 Aquastat Pocket
- 8 Boiler Flow
- 9 Incoloy Immersion (fact. fitted)
- 10 Secondary Return
- 13 T&P Relief Valve
- 14 Hot Water Draw Off
- 15 Solar Sensor
- 16 Solar / Boiler Flow
- 17 Solar / Boiler Return

Connection Sizes & Safety	170	200	250	300	400	500
Hot & Cold Conn. Ø (mm)	22	22	22	22	22	22
Primary Coil Connection Ø (mm)	22	22	22	22	22	22
Solar Coil Connection Ø (mm)	22	22	22	22	22	22
Secondary Return Ø BSP F (")	0.5	0.5	0.5	0.5	0.5	0.5
T&P Connection Ø BSP F (")	0.5	0.5	0.5	0.5	0.75	0.75
3bar	T&P Press. Set. (bar)	7	7	7	7	7
	Exp. Relief Set. (bar)	6	6	6	6	6

Dimensions	170	200	250	300	400	500
Cylinder Height (A, mm)	1310	1490	1815	1600	1570	1900
Cylinder Diameter (B, mm)	540	540	540	600	710	710
Connection Height C (mm)	196	196	196	218	225	225
Connection Height D (mm)	246	246	246	268	275	275
Connection Height E (mm)	346	386	416	438	430	430
Connection Height F (mm)	446	486	516	538	615	615
Connection Height G (mm)	511	551	581	603	680	680
Connection Height H (mm)	576	616	646	668	745	745
Connection Height I (mm)	681	756	786	810	888	888
Connection Height J (mm)	826	906	1031	1053	1130	1130
Connection Height K (mm)	882	981	1271	1153	1180	1440
Connection Height L (mm)	1031	1211	1531	1333	1280	1640

Performance	170	200	250	300	400	500
Heat Up Time ΔT 50°C	15	17	21	25	30	38
1° Re-Heat time (70% draw off) 60L/min	10	12	15	18	21	28
1° Re-Heat time (70% draw off) 15L/min fr. cold 45°C	15	17	21	25	30	38
Weight Empty (kg)	38	45	54	60	68	95
Weight Full (kg)	208	245	304	361	468	593
Prim. Coil Surf. Area (m ²)	0.58	0.58	0.64	0.64	0.77	0.77
Prim. Coil Rating @ 60L/min (kW)	20	20	21	21	23	23
Prim. Coil Rat. @15L/m (kW, 80±2°C)	20	20	21	21	23	23
Prim. Coil Press. Drop @ 15L/min (mbar)	45	65	76	76	88	90
Prim. Coil Press. Drop @ 60L/min (mbar)	42	42	65	65	76	76
Dedicated Solar Volume (ltr)	101	118	158	167	199	284
Solar Coil Surface Area (m ²)	0.58	0.67	0.77	0.77	1.15	1.28
Solar Coil Rating @ 60L/min (kW)	19	21	23	23	25	28
Cont. Output @60°C ΔT 50°C (L/hr)	382	382	401	401	440	440

Plumbing G3 Unvented Kit

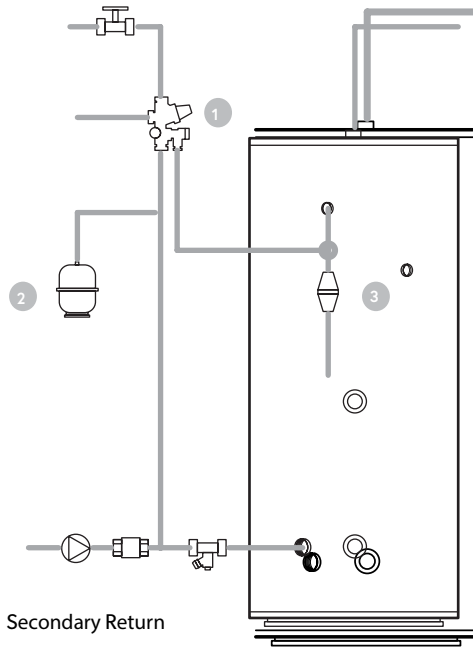

All unvented cylinders must have full G3 kit as supplied with cylinder installed correctly

Inlet Control Group Valve 1 must be fitted on incoming cold feed within 3m of cylinder

Potable Expansion Vessel 2 must be fitted on cold feed between Inlet Valve 1 and cylinder

Tundish 3 must be fitted on T&P and P relief as shown in this diagram and also reference to **page 43-45** Discharge Arrangement



Failure to install unvented kit correctly invalidate warranty and does not comply with Building Regulations.

Testing



Do not connect a 6kW Immersion without using a relay switch.

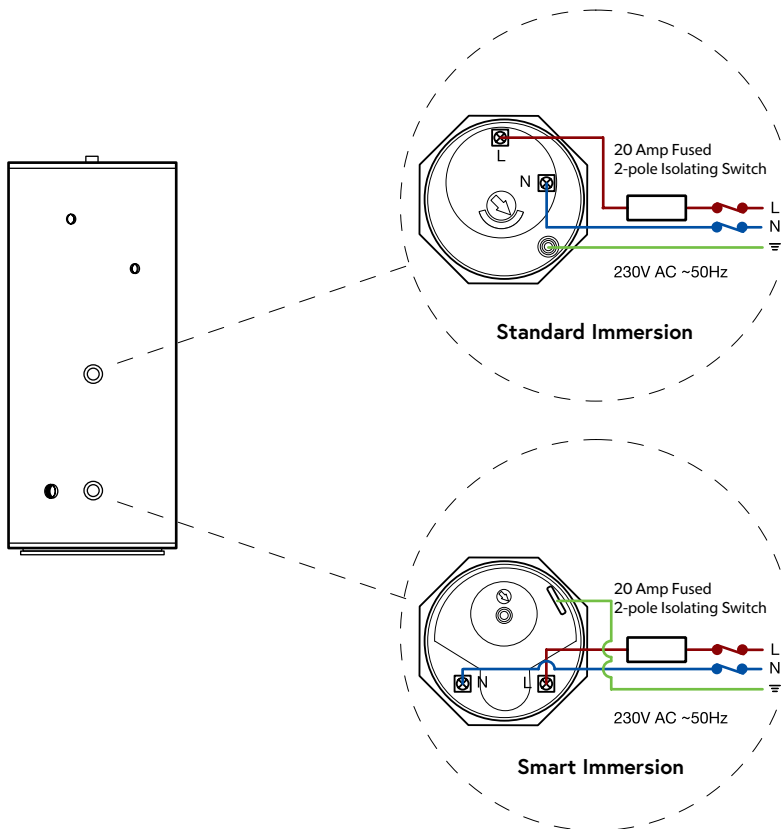

Fitting The Immersion Heater

Always check the immersion for signs of leakage before wiring commences.

The immersion heater must be completely submerged in water with a minimum of 200mm of water above the top of the immersion.



Do not operate the immersion heaters until the cylinder has been filled with water

Wire the immersion through a double pole fused spur. The contact separation must be no less than 3mm with a minimum breaking capacity of 16A.

Smart Immersion Functions

On the new Smart Immersion we have four setting options:

- **OFF**
- **ECO** – smart control: starts for 2 weeks at 70°C and then it will select automatically storage temperatures through the day
- **MANUAL** – works as standard mechanical thermostat can be set up to 70°C
- **OPK** (off peak) – this must be selected when the cylinder is connected to the night tariff. During the day time the immersion is not connected and this would require the smart control to be reset. When OPK is selected it should be set at 60°C and working as a standard thermostat. Alternatively the user can select the manual mode.

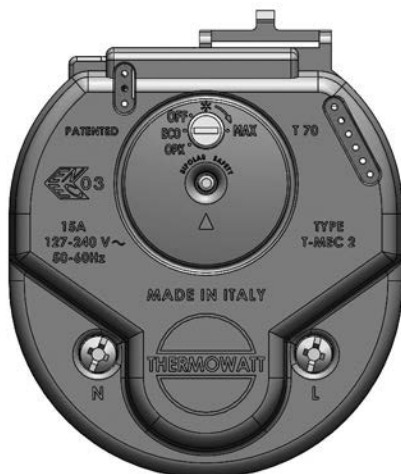

Immersion Installation

1. Check your mains power voltage matches the voltage rating indicated on the label of the plastic terminal cover.
2. The immersion heater must be fixed to the cylinder using the gasket provided. Please ensure that the unit is not over tightened into the tank boss. Silicon sealant on the gasket is recommended.



This heater should only be installed in systems where the element is always below water level, such as a cistern fed tank. Check that there is water in the tank before the immersion heater is first switched on.

If the heater is allowed to run when the water level is not fully covering the heating element there may be serious damage incurred to the heater, property or persons. The appliance is not to be used by children or persons with reduced physical, sensory or mental capabilities, or lack of experience and knowledge, unless they have been given supervision or instruction concerning use of the appliance by a person responsible for their safety. Children should be supervised to ensure that they do not play with the appliance.

Thermostat Information

The immersion heater is supplied with a T-MEC 2 Electronic thermostat. To maintain safety, any thermostat replacement must be of the same type.



Low water temperature is recommended to reduce limestone deposit (not lower than 60°C)

The thermostat in this unit is able to disconnect both supply conductors (live and neutral) by a single initiating action. It has a safety resettable cut out mechanism which prevents excessive temperatures. In case the normal sensing device fails, the over temperature safety device will act to limit the water over-temperature.

To reset the thermostat after an intervention of the safety device:

1. Switch off the heater by isolating the power supply
2. Allow the water in the cylinder to cool down sufficiently
3. Remove the cover and press the button on the top of the thermostat.

NB: This cut out is a safety device, if this is found to be operating frequently then we recommend to consult a qualified electrician to investigate the nature of the problem as the thermostat may need to be replaced. It may be helpful to lower the thermostat setting to avoid unnecessary cut offs.

Knob setting position

The Thermowatt TMEC-2 Electronic Thermostat has 5 operating modes, and is supplied set to the maximum control temperature of 70°C. To select the alternative modes the adjustment knob is turned anticlockwise, until the slot in the adjustment knob is in line with the required mode:



ECO – Smart mode Factory Setting – This setting gives maximum energy efficiency and uses smart technology to learn the user’s habits to control water temperature to suit demand. During the first week the thermostat will run at 70°C whilst recording hot water usage, then the following and each subsequent week it adjusts automatically to give the most efficient use of electricity. In the event of any power loss the thermostat will lose all recorded data, and will restart learning mode. Antibacterial mode will function.



Changing thermostat setting from the factory pre-set position may impact upon the efficiency rating of the cylinder in which it is fitted.



OPK – Basic Electronic Thermostat mode – With the control knob turned on this position the thermostat will control water temperature to maximum 60°C and is unaffected by any interruption of power supply. Use this position for manual switching or by timer such as economy type installations. Antibacterial mode will function.



OFF – In this mode the thermostat will not operate, only the double pole safety cut out will function. Antibacterial mode will NOT function.



Antifreeze mode – This setting will maintain a minimum water temperature of 20°C to prevent the water heater from freezing. Antibacterial mode will function.



MAX – Maximum temperature in Manual Mode – With the control knob turned clockwise to the MAX setting the thermostat will control water temperature to a maximum of 70°C. The water temperature can be adjusted to a lower setting by turning the adjustment knob anticlockwise up to 80° where the lowest setting is approximately 10°C. Antibacterial mode will function.

Electrical Connections

1. This unit should be connected by a suitably qualified electrician in accordance with the latest I.E.E. regulations.
2. Ensure the electrical supply is switched off before making any connection to the unit.
3. The immersion heater must be wired through a double pole isolating switch with contact separation of at least 3mm in both poles.
4. The immersion heater must be wired with a heat resistant flexible cord with a minimum T rating of "T-80" and with a minimum cross-section area of 1.5mm².
5. Ensure that the terminal screws are not over tightened as this could result in the terminations being broken off.



This device must be earthed wiring

1. Earth connection (green & yellow) should be made firmly to the earth post (marked "E") using the terminals attachments provided.
2. The Live Supply (brown) from the mains supply cable to the thermostat terminal marked "L"
3. The Neutral connection (blue) from the mains supply cable to the thermostat terminal marked "N"

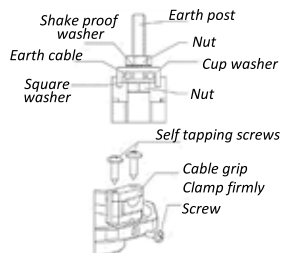
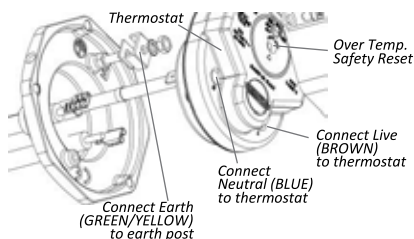

Un-Plumbed Cylinder Schematic

Mechanical Diagram S-Plan

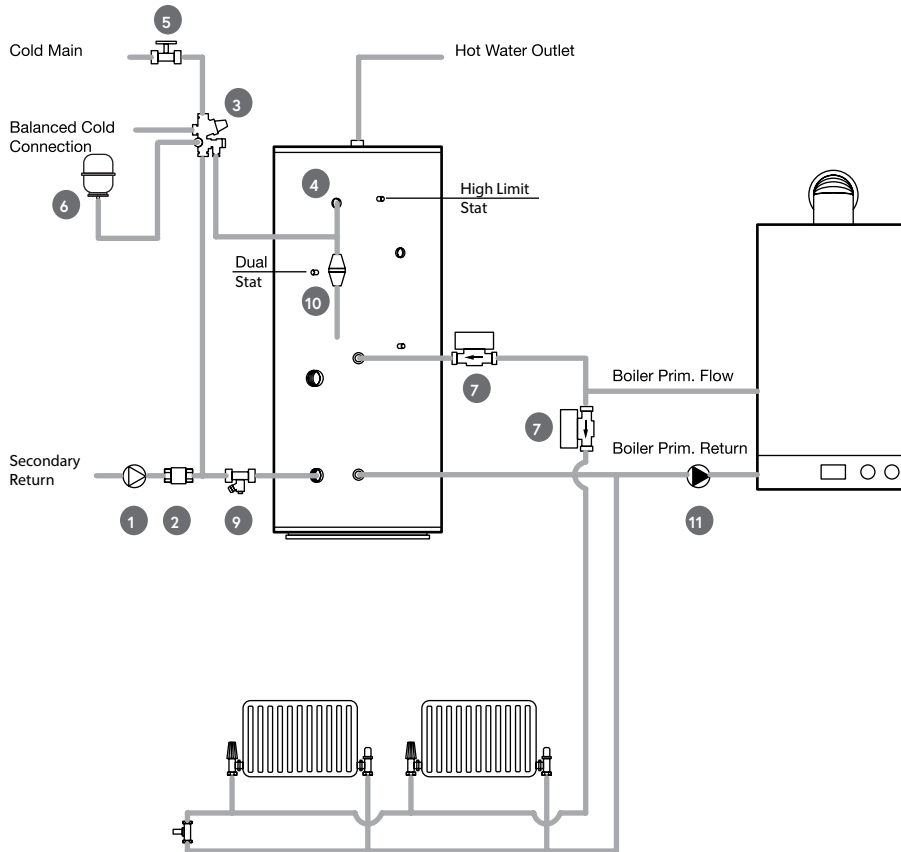

- 1 Bronze Pump
- 2 Non Return Valve (not supplied)
- 3 Inlet Control Group
- 4 Temperature & Pressure Relief Valve
- 5 Isolation Valve (not supplied)
- 6 Exp. Vessel with Wall Bracket
- 7 2-port Zone Valve (one only supplied)
- 9 Drain Valve (not supplied)
- 10 Tundish
- 11 Heating Circ. Pump (not supplied, required with heat only boiler)

Un-Plumbed Cylinder Schematic

Electrical Diagram S-Plan

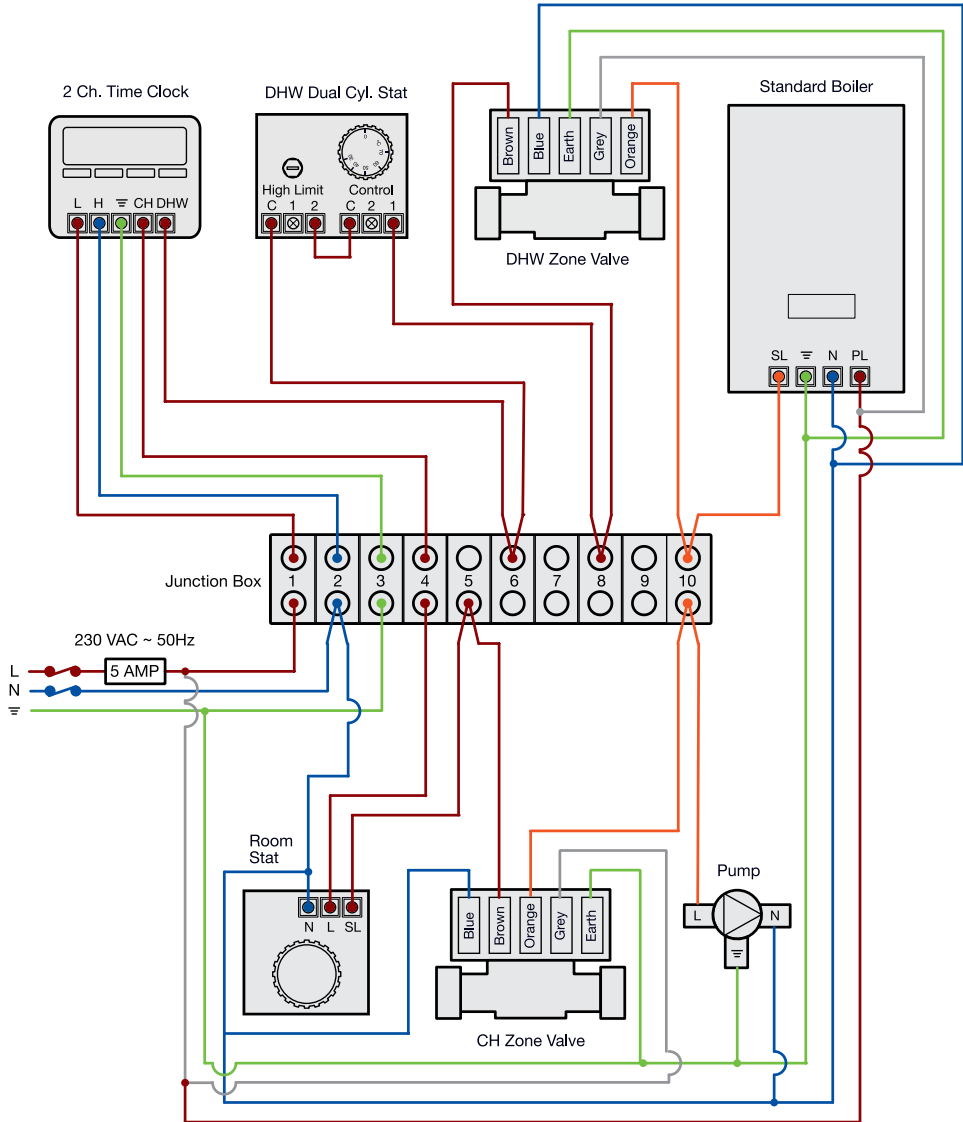

Un-Plumbed Cylinder Schematic

Mechanical Diagram Y-Plan

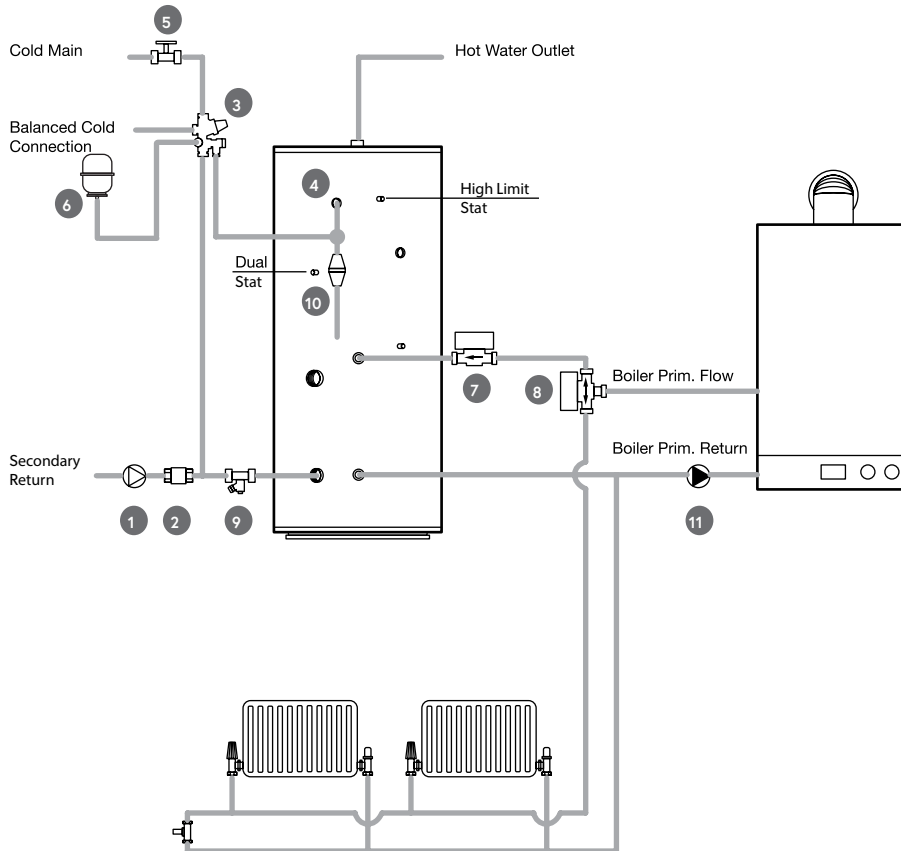

- 1 Bronze Pump
- 2 Non Return Valve (not supplied)
- 3 Inlet Control Group
- 4 Temperature & Pressure Relief Valve
- 5 Isolation Valve (not supplied)
- 6 Exp. Vessel with Wall Bracket
- 7 2-port Zone Valve
- 8 3-port Valve (not supplied)
- 9 Drain Valve (not supplied)
- 10 Tundish
- 11 Heating Circ. Pump (not supplied, required with heat only boiler)

Un-Plumbed Cylinder Schematic

Electrical Diagram Y-Plan

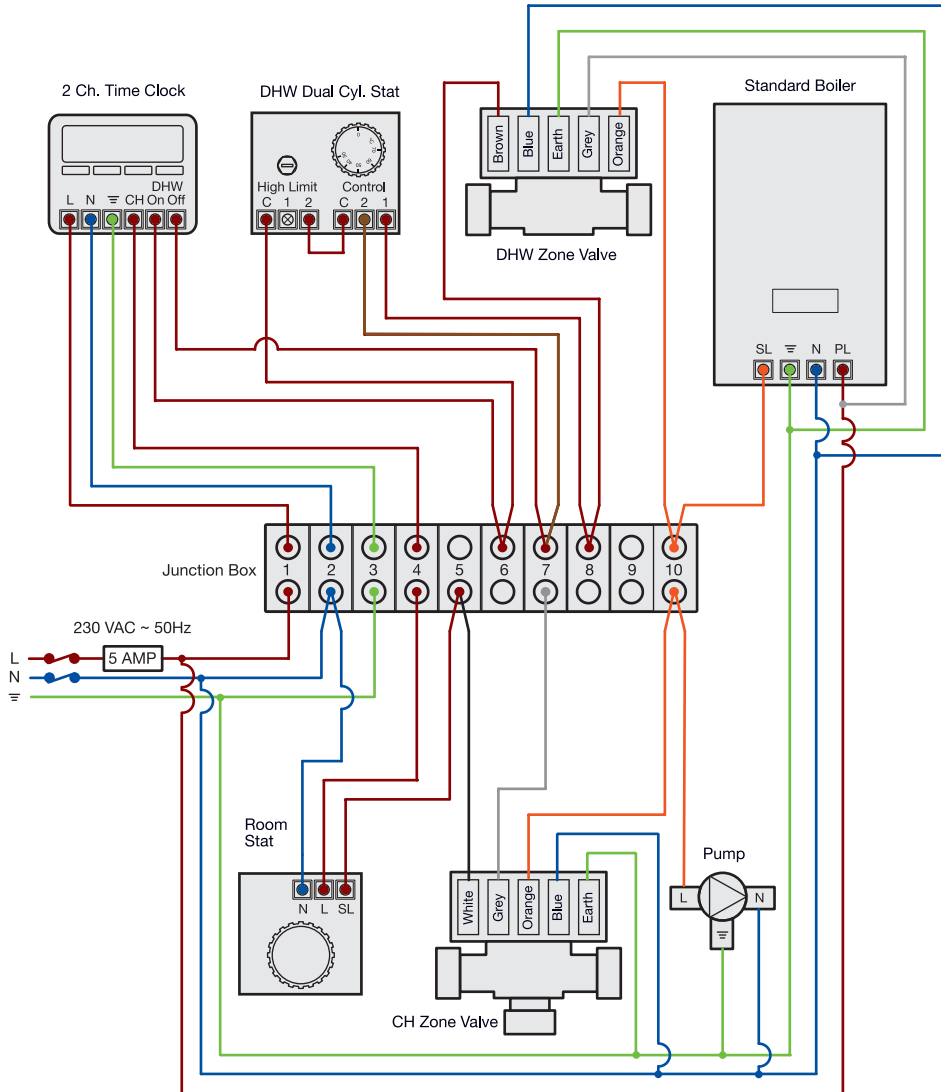

Electronic Controls

Electrical Controls

Suitable time and temperature controls should be installed to allow the cylinder to operate at its maximum efficiency. All electrical work carried out must comply with IEE Wiring Regulations (BS 3456). Products must also be installed as per the regulations in G3 of the Building Regulations. A boiler interlock should be in place and is a wiring arrangement where the boiler cannot fire unless there is a demand for hot water generation.

Typical Wiring Diagrams

These diagrams relate only to the components listed. Others may vary in their wiring requirements, particularly thermostats. Always refer to manufacturers' instructions which may override the detail in order to function correctly.

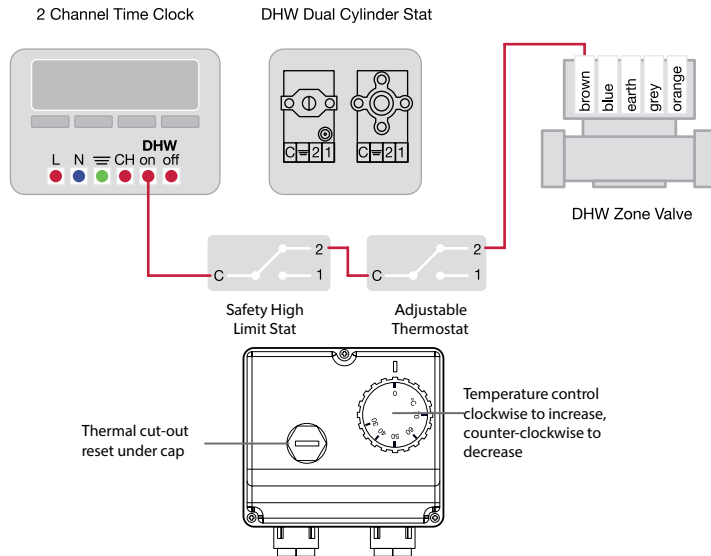

The link must be installed between the adjustable thermostat and the safety cut-out thermostat as shown above. The operating thermostat which controls the temperature of the domestic hot water is adjustable. A safety cut out is also incorporated within the thermostat and will operate at $85^{\circ}\text{C} \pm 3^{\circ}\text{C}$. Both thermostats should run in series. To reset the safety cut-out and the motorised valve the reset button must be pressed in.

Joule™ cannot be responsible if alternative wiring plans are used.



Before resetting the safety cut-out or altering the thermostat setting, isolate electrical supply to the unit before removal of the cover.

Discharge Arrangement

Discharge Pipework

The inlet control group should be positioned so that the discharge from both safety valves can be combined via a 15mm end feed tee. Connect the tundish and route the discharge pipe which must be routed in accordance with Building Regulations - Part G3 of schedule 1.

When operating normally water will not be discharged. Water discharge from the two safety valves will only occur under fault conditions. The tundish should be vertical, located in the same space as the unvented hot water storage system and be fitted as close as possible, and lower than the valve, with no more than 600mm between the safety device outlet e.g. the temperature relief valve and the tundish.

The position of the tundish must be that when installed it is visible to the occupants of the premises. When positioning the tundish, the drain valves and motorised valve ensure that these items are positioned away from any electrical devices. The discharge pipe (D2) coming from the tundish should terminate in a safe place where there is no risk to persons in the vicinity of the discharge, be of metal and:

- Be at least one pipe size larger than the nominal outlet size of the safety device unless its total equivalent hydraulic resistance exceeds that of a straight pipe 9m long, i.e. discharge pipes between 9m and 18m equivalent resistance length should be at least two sizes larger than the nominal outlet size of the safety device, between 18 and 27m at least 3 sizes larger, and so on.
- Bends must be taken into account in calculating the flow resistance. Refer to diagram 1, Table 1 and the worked example. An alternative approach for sizing discharge pipes would be to follow BS6700 Specification for design, installation, testing and maintenance of services supplying water for domestic use within buildings and their curtilages.
- Have a vertical section of pipe at least 300mm long, below the tundish before any elbows or bends in the pipework.
- Be installed with a continuous fall.

It is preferable for the discharge to be visible at both the tundish and the final point of discharge. Where this is not possible or practically difficult, there should be clear visibility at one or other of these locations.

Discharge Arrangement

Examples Of Acceptable Discharge Arrangements

Ideally below the fixed grating and above the water seal in a trapped gully.

Downward discharges at a low level ; i.e. up to 100mm above external surfaces such as car parks, hard standings, grassed areas etc. are acceptable providing that where children play or otherwise come into contact with discharges, a wire cage or similar guard is positioned to prevent contact whilst maintaining visibility.

Discharges at a high level ; e.g. in to metal hopper and metal down pipe with the end of the discharge pipe clearly visible (tundish visible or not) or onto a roof capable of withstanding high temperature discharges of water and 3m from any plastic guttering systems that would collect such discharges (tundish available).

Where a single pipe serves a number of discharges, such as in blocks of flats, the number served should be limited to not more than 6 systems so that any installation can be traced reasonably easily.

The single common discharge pipe should be at least one pipe size larger than the largest individual discharge pipe to be connected. If unvented hot water storage systems are installed where discharges from safety devices may not be apparent, i.e. in dwellings occupied by blind, infirm or disabled people, consideration should be given to the installation of an electronically operated device to warn when discharge takes place.

Worked Example

The example on the next page is for G1/2 temperature relief valve with a discharge pipe (D2) having 4 No. elbows and length of 7m from the tundish to the point of discharge.

Maximum resistance allowed for a straight length of 22mm copper discharge pipe (D2) from a G1/2 temperature relief valve is: 9.0m. Subtract the resistance for 4 No. 22mm elbows at 0.8m each = 3.2m. Therefore the maximum permitted length equates to: 5.8m. 5.8m is less than the actual length of 7m, therefore calculate the next largest size.

Maximum resistance allowed for a straight length of 28mm pipe (D2) from a G1/2 temperature relief valve equates to: 14m. As the actual length is 7m, a 28mm (D2) copper pipe will be satisfactory.

	G 1/2			G 3/4			G1		
Min. size of discharge pipe D1	15mm			22mm			28mm		
Min. size of discharge pipework D2 from tundish	22mm	28mm	35mm	28mm	35mm	42mm	35mm	42mm	54mm
Max. length of straight pipe (no bends or elbows)	Up to 9m	Up to 18m	Up to 27m	Up to 9m	Up to 18m	Up to 27m	Up to 9m	Up to 18m	Up to 27m
Deduct the gure below from the maximum length for each bend or elbow in the discharge pipe	0.8m	1.0m	1.4m	1.0m	1.4m	1.7m	1.4m	1.7m	2.3m

Sizing of copper discharge pipe (D2) for a temp. relief valve with a G1/2 outlet size (as supplied)

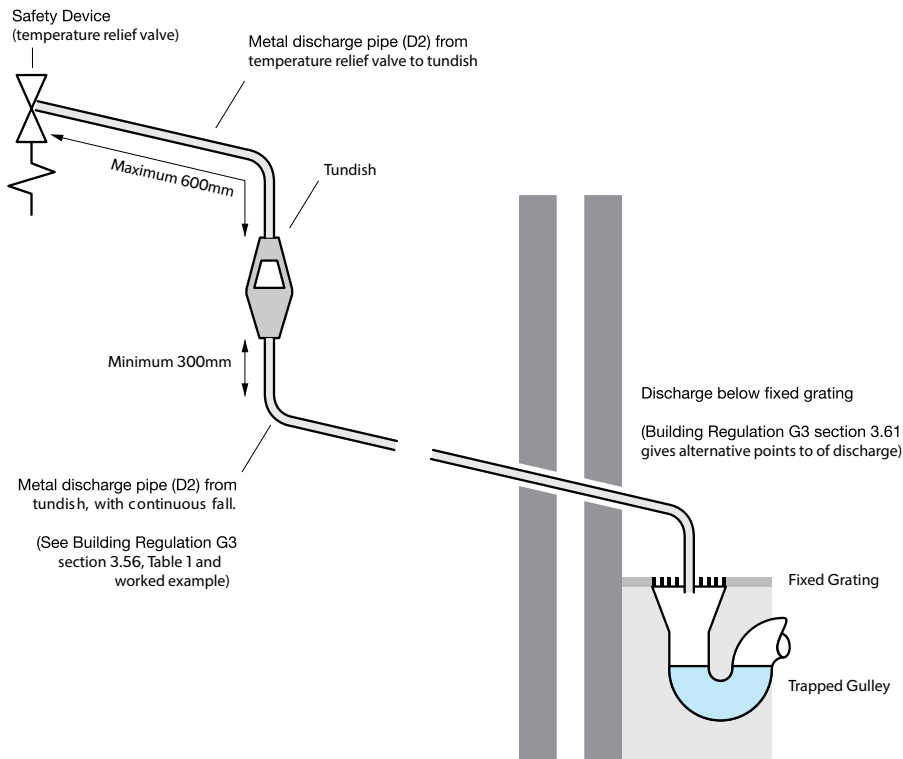

The discharge will consist of scalding water and steam. Asphalt, roofing felt and non-metallic rainwater goods may be damaged by such discharges.

It is not acceptable to discharge straight into a soil pipe.

Commissioning

Filling

First you must ensure that the pressure in the expansion vessel is the same as the setting of the pressure reducing valve i.e. 3 bar (45PSI). The valve is of the Schrader car tyre type. Check all the connections for water tightness including any factory made connections such as the immersion heater and the temperature and pressure relief valve. Prior to filling, open the hot tap furthest away from the cylinder to expel air. Open the cold main isolation valve and allow the unit to fill.

Once the cylinder has been fully commissioned it should be heated to its normal operating temperature. Draw off secondary hot water to each outlet and allow hot water to flow from each outlet for at least 30 seconds to remove any flux residue from the pipe work within the secondary hot water system. Then fully drain the cylinder and re-fill to ensure that all flux residues are removed from the system.

Indirect Units

Fill the primary circuit according to the boiler manufacturers' commissioning instructions. Any additives used in the heating system water circulating through the cylinder coil must be compatible for use with stainless steel cylinders.

Ensure the lever on the two port valve is set to the filling position. When full, move the lever back. Switch the programmer to Domestic Hot Water (DHW) and allow the unit to start to heat. Adjust the dial of the dual thermostat to between 30°C and 70°C as required.

Storage Temperature

60-65°C is the recommended storage temperature for both direct and indirect cylinders. In hard water areas consideration should be given to reducing this to 50-55°C. In many healthcare applications the guidance on Legionella control and safe water delivery temperatures will require storing the water at 60-65°C, distributing at 50- 55°C and using thermostatic mixing valves to control the final temperature. For details consult the NHS Estates Guidance on safe hot water temperatures.

Maintenance

General

Servicing should only be carried out by competent installers and any spare parts used must be purchased from Joule™.



Never bypass any safety devices or operate the unit without them being fully operational

Draining

Switch the electrical power off (important to avoid damage to element). Isolate boiler from the unit. Turn off the cold water supply valve. Open hot water tap. Open the drain valve. The unit will drain.



Water drained off may be very hot!

Annual Maintenance

The water heaters require annual servicing in order to ensure safe working and optimum performance. It is essential that the following checks are performed by a competent installer on an annual basis. This is commonly done at the same time as the annual boiler service.

- Twist the cap of the expansion relief valve on the inlet control set and allow water to flow for 5 seconds. Release and make sure it resets correctly.
- Repeat with the pressure / temperature relief valve. In both cases check that the discharge pipework is carrying the water away adequately. If not, check for blockages etc. and clear.
- Check that any immersion heaters fitted are working correctly and that they are controlling the water at a temperature between 55°C and 65°C.
- Check the pressure in the expansion vessel is charged to 3 bar. Turn off the water supply to the unit and open a hot tap first. The air valve on expansion vessel is a Schrader (car tyre) type.
- Air or CO₂ may be used to charge the expansion vessel. Unscrew the head on the inlet control set and clean the mesh filter within.

The Service Log Book supplied with this unit should be updated at each service.



Your guarantee may be void if you cannot produce proof of annual servicing immersion heater replacement.

Immersion Heater Replacement

If the thermal cut out on the Immersion heater operates contact a competent installer. If the thermal cut out fault occurs again the immersion will need to be replaced.

Prior to installing the replacement Immersion, ensure the o-ring is correctly positioned on the head of the Immersion and lubricate the threads before fitting.

Thread the Immersion by hand until it is hand tight and then tighten gently to allow the o-rings to create a water tight seal.

Inspection

Where internal inspection of the cylinder is required an endoscope can be used. Inspection can be carried out by draining down the cylinder and removing a component that is fitted to a wet connection in the cylinder.

Safety Valve Checks

Water discharges from either the temperature/pressure relief valve or the expansion relief valve indicates a problem.

- Check your discharge pipework is free from debris and is carrying water away to waste effectively.
- Next hold both of these safety valves open, allowing as much water as possible to flow through the tundish.
- Release the valves and check that they reseal correctly.



Completion of the Benchmark Checklist on pages 52-53 must be adhered to by the installer

Taking The Cylinder Out Of Use

Shutting Down

- Ensure the cold water supply is isolated and at least two hot water draw off points are open prior to draining the cylinder.
- One of the hot water draw off points should be as close as possible to the height of cylinder in draw off terms.
- Where applicable use the drain valve at the cold water inlet to drain the contents of the cylinder.
- Isolate the coil from the main heating system. If necessary blow out the coil prior to moving the cylinder.

Recycling And Disposal

The cylinder or any of its components must not be disposed of in domestic rubbish. The material in the cylinder, packaging and components contain recyclable materials and they should be disposed of properly and in accordance with national regulations.

Guidance In The Event Of A Problem

In the event of a problem please contact your installer and the contact details in this installation manual.

Log Book

The installer must comply with all of the installation instructions contained within this installation manual. On completion of the initial installation and after each subsequent annual service the Benchmark Log Book must be completed and signed by the competent person who has worked the unit.

The purpose of Benchmark is to ensure that customers have the correct equipment for their requirements installed in accordance with the manufacturer's installation instructions. The equipment must be installed by installers who have completed an accredited competent person's scheme and who install, commission and service the equipment in accordance with the manufacturer's instructions.

All installations must comply with the appropriate Building Regulations and the Benchmark Log Book should be provide to the customer. The Benchmark Log Book can also be used to show that all equipment is installed in accordance with the relevant Building Regulations.

Troubleshooting

Your stainless system is automatic in normal use and requires only annual servicing. You should employ a competent installer to perform the annual servicing. Normally this is timed to coincide with the annual boiler service.



If water is flowing from the safety valves through the tundish this indicates a fault condition and action is needed.

If this water is hot, turn the boiler and / or the immersion heater off. Do not turn off the water until the discharge runs cool. The discharge may also stop.

CALL OUT A COMPETENT PLUMBER TO SERVICE THE UNIT.

Tell them you have a fault on an unvented cylinder. We stock all the spare parts they may need and Joule™ can be contacted via telephone numbers on back page.

Fault	Possible Cause	Solution
Water escaping from the case unit.	Compression fitting on hot - draw off not sealing.	Check / remake joint sealing paste.
Cold water at hot tops.	Immersion heater not switched on or cutout has triggered.	Check / reset.
	Indirect - Boiler not working.	Check boiler - consult boiler manufactures' instructions.
	Indirect - motorized valve fault.	Check plumbing / wiring motorized valve.
	Indirect - cutout in dual stat has operated.	Check for faults in the thermostat or high limit stat and reset.
Water discharges from expansion relief valve	If continual - pressure reducing valve (part of inlet control set) may not be operating correctly.	Check outlet pressure from inlet control set is 3 bar.
	If continual - expansion relief valve seat may be damaged.	Remove cartridge - check seat and renew if necessary.
	If intermittent - expansion vessel charge may have reduced / bladder perished.	Check pressure in expansion vessel. Recharge to 3 bar if necessary. If bladder perished replace vessel.
	Unit is being back pressurized.	With cylinder cold check pressure in cylinder. If this is the same as the incoming mains pressure then you are getting backfeed. Install a balanced cold supply.
Water discharges from temperature & pressure relief valve	Unit has overheated - thermal controls have failed.	Switched off power to boiler and immersion heaters. Leave water supply on. Wait until discharge stops. Isolate water supply and replace if faulty.
Milky / cloudy water	Oxygenated Water.	Water from any pressurized system will release oxygen bubbles when flowing. The bubbles will settle out.
No hot water flow	Cold main off.	Check and open stopcock.
	Strainer blocked in pressure reducing valve.	Isolate water supply and clean.
	Inlet control set may be fitted incorrectly.	Check and refit if required.
Noise during hot water draw off - typically worse in the morning	Loose airing cupboard pipework.	Install extra clips.
Hot or warm water from cold tap	If tap runs cold after a minute or so the pipe is picking up heat from heating pipework.	Insulate/re-route.

Benchmark Checklist

SYSTEM COMMISSIONING CHECKLIST

This Commissioning Checklist is to be completed in full by the competent person who commissioned the storage system as a means of demonstrating compliance with the appropriate Building Regulations and then handed to the customer to keep for future reference.

Failure to install and commission this equipment to the manufacturer's instructions may invalidate the warranty but does not affect statutory rights.

Customer Name _____ Telephone Number _____

Address _____

Cylinder Make and Model _____

Cylinder Serial Number _____

Commissioned by (*print name*) _____ Registered Operative ID Number _____

Company Name _____ Telephone Number _____

Company Address _____

Commissioning Date _____

To be completed by the customer on receipt of a Building Regulations Compliance Certificate*:

Building Regulations Notification Number (*if applicable*) _____

ALL SYSTEMS PRIMARY SETTINGS (*indirect heating only*)

Is the primary circuit a sealed or open vented system? Sealed Open

What is the maximum primary flow temperature? _____ °C

ALL SYSTEMS

What is the incoming static cold water pressure at the inlet to the system? _____ bar

Has a strainer been cleaned of installation debris (if fitted)? Yes No

Is the installation in a hard water area (above 200oom)? Yes No

If yes, has a water scale reducer been fitted? Yes No

What type of scale reducer has been fitted? _____

What is the hot water thermostat set temperature? _____ °C

What is the maximum hot water flow rate at set thermostat temperature (measured at high flow outlet)? _____ l/min

Time and temperature controls have been fitted in compliance with Part L of the Building Regulations? Yes

Type of control system (if applicable) Y Plan S Plan Other

Is the cylinder solar (or other renewable) compatible? Yes No

What is the hot water temperature at the nearest outlet? _____ °C

All appropriate pipes have been insulated up to 1 metre or the point where they become concealed Yes

UNVENTED SYSTEMS ONLY

Where is the pressure reducing valve situated (if fitted)?

What is the pressure reducing valve setting? bar

Has a combined temperature and pressure relief valve and expansion valve been fitted and discharge tested? Yes No

The tundish and discharge pipework have been connected and terminated to Part G of the Building Regulations Yes

Are all energy sources fitted with a cut out device? Yes No

Has the expansion vessel or internal air space been checked? Yes No

THERMAL STORES ONLY

What store temperature is achievable?

°C

°C

°C

ALL INSTALLATIONS

The hot water system complies with the appropriate Building Regulations Yes

The system has been installed and commissioned in accordance with the manufacturer's instructions Yes

The system controls have been demonstrated to and understood by the customer Yes

The manufacturer's literature, including Benchmark Checklist and Service Record, has been explained and left with the customer Yes

Commissioning Engineer's Signature _____

Customer's Signature _____

(To confirm satisfactory demonstration and receipt of manufacturer's literature)

*All installations in England and Wales must be notified to Local Authority Building Control (LABC) either directly or through a Competent Persons Scheme. A Building Regulations Compliance Certificate will then be issued to the customer.



Service Record

It is recommended that your hot water system is serviced regularly and that the appropriate Service Record's completed.

Service Provider

Before completing the appropriate Service Record below, please ensure you have carried out the service as described in the manufacturer's instructions.

Service 1 Date

Engineer Name

Company Name

Telephone No

Comments

.....

.....

Signature

Service 2 Date

Engineer Name

Company Name

Telephone No

Comments

.....

.....

Signature

Service 3 Date

Engineer Name

Company Name

Telephone No

Comments

.....

.....

Signature

Service 4 Date

Engineer Name

Company Name

Telephone No

Comments

.....

.....

Signature

Service 5 Date

Engineer Name

Company Name

Telephone No

Comments

.....

.....

Signature

Service 6 Date

Engineer Name

Company Name

Telephone No

Comments

.....

.....

Signature

Service 7 Date

Engineer Name

Company Name

Telephone No

Comments

.....

.....

Signature

Service 8 Date

Engineer Name

Company Name

Telephone No

Comments

.....

.....

Signature

Service 9 Date

Engineer Name

Company Name

Telephone No

Comments

.....

.....

Signature

Service 10 Date

Engineer Name

Company Name

Telephone No

Comments

.....

.....

Signature

JOULE IE

Unit 407 NW Business Park,
Cappagh Road, Ballycoolin,
Blanchardstown, Dublin

tel +353 (1) 623 7080
fax +353 (1) 626 9337
mail info@joule.ie
web www.joule.ie

JOULE PL

Strzegomska 55D,
53-611 Wrocław, Polska

tel +48 (0) 128811171
fax +48 (0) 814709046
mail biuro@joule-pl.pl
web www.joule-pl.pl

JOULE UK

Unit 1 & Unit 3,
Leftfield Park, Park Road, West Yorkshire,
WF8 4PS, United Kingdom

tel +44 (0) 330 808 8488
fax +44 (0) 1513 568 336
mail info@jouleuk.co.uk
web www.jouleuk.co.uk